

MC4

DOCUMENTING PROCESS CALIBRATOR



User Guide

Dear user,

We have made every effort to ensure the accuracy of the contents of this manual. Should any errors be detected, we would greatly appreciate to receive suggestions to improve the quality of the contents of this manual.

The above notwithstanding, we can assume no responsibility for any errors in this manual or their eventual consequences.

We reserve rights to make modifications to this manual without any further notice.

For more detailed technical data about the MC4 Documenting Process Calibrator, please contact the manufacturer.

© 2008-2016

BEAMEX OY AB

Ristisuonraitti 10

FIN-68600 Pietarsaari

FINLAND

Tel +358 - 10 - 5505000

Fax +358 - 10 - 5505404

E-mail: sales@beamex.com

Internet: <http://www.beamex.com>

8811000 / MC4uEng / Version 3e

Trademarks and Statements

QCAL® is a registered trademark owned by Beamex Oy Ab.
Other trademarks are property of their respective owners.

MC4 contains licensed software which requires that the source code is available for You. Please contact Beamex to obtain it.

MC4 is based in part on the work of the FLTK project
(<http://www.fltk.org>).

Contents

Part A, General

Introduction	2
About This Manual	3
Typographical Conventions	3
Unpacking and Inspection	4
MC4 Hardware	5
Connections	6
Pressure Modules	7
Connectors on the Left Side of MC4	8
Terminals	8
Support for Table Top Use	9
Memory	9
Display.....	9
Keyboard	10
Batteries	11
About the Charger and the Charging Procedure	12
Removing/Replacing the Batteries.....	13
Capacity Indication.....	14
PC Communication with USB	15
MC4 Firmware	16
General Description.....	16
Startup Procedure	16
Basic Mode and Higher Level Functions	16
Instrument Database and Instrument Calibration	16
Basic Mode's User Interface	17
The Status Bar	17
Windows 1 and 2	17
The Function Key Bar	18
Menu	18
Configuration Windows	19
Field Types Available for Editing Data	20

MC4 Options	24
Hardware Modules/Options.....	24
Other Devices.....	25
Safety	26
Symbols Used	26
Safety Precautions and Warnings.....	27
General Warnings	28
Warnings Concerning Electrical Measurement and Generation.....	28
General Warnings Concerning Pressure Measurement.....	29
Warnings Concerning High Pressure	30
Disposal of Waste Electrical and Electronic Equipment	31
Service	32
Firmware Update.....	32
The Battery Charger.....	32
Resetting MC4	32
Recalibrating MC4.....	33
Cleaning MC4.....	33

Part B, Startup and Basic Operation

Starting MC4	36
Startup Procedure	36
Basic Mode, Defined	37
Measuring	39
Current Measurement	41
Frequency Measurement	42
Pressure Measurement	43
Connecting and Disconnecting External Pressure Modules	44
Zeroing a Pressure Module.....	45
Pulse Counting	46
Resistance Measurement	47
Switch State Sensing	48
Temperature Measurement (RTD).....	50
Temperature Measurement (Thermocouple)	51
Voltage Measurement	52
Generating/Simulating	53
Changing the Generated/Simulated Value.....	54
Spinning and Manual Stepping	54
Current Generation.....	56
Frequency Generation	58
Pulse Generation.....	59
Resistance Simulation.....	60
RTD Sensor Simulation.....	61
Thermocouple Simulation	63
Voltage Generation	65
Manually Keyed Values	66
Tools Menu	67
Function Info.....	68
Alarms	69
Damping.....	70
Leak/Stability Test.....	71
Stepping	73
Ramping.....	76
Manual Stepping	78
Display Mode and Special Measurements.....	81
Error %	82

Error in Input Units	83
Error in Output Units	84
Percentage.....	85
Scaling	86
Deviation	87
Redundant	88
Difference.....	89
Showing Data on the Additional Info Row.....	90
Resetting and Clearing Additional Info Row / Calculations.....	93

Part C, Advanced Operation and Configurations

Utilities Menu	96
About This Calibrator	96
Instrument Calibration	97
User Setups for ❶ & ❷	97
Date/Time	98
General Settings.....	99
Calibrator Adjustment.....	100
Custom Test Point Sets.....	101
Custom Transfer Functions	103
Custom PRT Sensors	106
Creating Custom PRT Sensors	106
Callendar - van Dusen Equation	107
Custom Pressure Units	108
Related Information	109
Things to Consider when Measuring Pressure	110
General	110
Pressure Type.....	110
Pressure Modules and their Naming Conventions	111
Square Rooting	112
Thermocouple Measurement/Simulation, Connections and Troubleshooting.....	113
Internal Reference Junction	113
External Reference Junction	114
Error situations	117
Resistance and RTD Measurement, Connections	118
4-wire System	118
3-wire System	118
Using a Compensation Loop.....	119
2-wire System	119
Current Measurement Parallel to a Test Diode, Connections.....	120
Parallel Functions in MC4	121

Part D, Calibration

General	124
Phases of Instrument Calibration	125
As Found Calibration	126
Adjustment	126
As Left Calibration.....	127
Supported Input/Output Signal Combinations.....	128
About Instrument Calibration.....	129
Selecting the Instrument to Be Calibrated	129
A Calibration Procedure Using MC4	130
Examples of Instrument Calibration	133
Pressure Transmitters.....	134
Temperature Indicators and Recorders	136
Temperature Sensors	138
Pneumatic Pressure Transmitters and Converters.....	140
Electrical Limit Switches	142
Calibration Window Menu	145
Menu When Calibration is NOT Started.....	145
Menu When a Calibration is Running.....	147
Tools Submenu	149
Maintaining MC4's Instrument Database	150
Instrument List Window Menu	152
Editing Instrument Data.....	156
Position Data Page	157
Device Data Page	158
Input Data Page	159
Output Data Page	161
Function Data Page	163
Procedure Data Page	165
Error Limits Data Page.....	170
General Data Page	172
Saving an Edited Instrument.....	173
Viewing Calibration Results	174
Calibration Result Windows	174
How to Choose Which Calibration Run is Viewed	175
Deleting Calibration Results	176

Additional Calibration Related Information.....	177
Extra Information Saved With Calibration Point Data	177
Accepting Calibration Points Automatically.....	178
Changing the Pressure Module During Calibration.....	179
Zeroing a Pressure Module During Calibration	180
Guidance Texts	180
Environmental Data.....	180
Error Calculation Formulas	181
Combining Calibration Repeats	182
Results and Memory Usage.....	182

Appendixes

Appendix 1, Technical Data	184
MC4 General Specifications	184
Electrical Measurements	185
Voltage Measurement	185
Current Measurement	185
Frequency Measurement	186
Pulse Counting	186
Switch Test	186
Electrical Generation, Sensor Measurement and Simulation	187
mV Measurement (T/C-Terminals)	187
mV Generation (T/C-Terminals)	187
Voltage Generation	188
mA Generation (Source/Sink)	188
Resistance Measurement	189
Resistance Simulation	189
Frequency Generation	190
Pulse Generation	190
Temperature Measurement and Simulation	191
RTD Measurement and Simulation	191
Thermocouple Measurement and Simulation	194
Pressure Modules	198
Internal Pressure Modules (NPM)	198
External Pressure Modules (EXT), High Accuracy	200
External Pressure Modules (EXT), Standard Accuracy	202
Appendix 2, Index	203

Feedback

We want to improve our products and services constantly. Therefore we'd like to know Your opinion of the product You use. Please spend a moment of Your valuable time in filling this form. All respondents will receive a surprise gift in return.

Certain questions can be answered immediately after receiving the product. Others require some use of the product before You are able to answer them. The best way to fill the form is to answer the items as it applies, and send the form to us when all items are answered. There are however no definite restrictions; fill in the form when you feel like it (all items need not be answered). Then send it to Beamex using one of the possibilities listed below.

Mail: **Beamex Oy, Ab**
Quality Feedback
P.O. Box 5
68601 Pietarsaari
FINLAND

Fax **+358 - 10 - 5505404**
Only the next page need to be faxed to us.

Internet: **<http://www.beamex.com>**
A similar form is available as a web page

E-mail: **support@beamex.com**
Refer to the numbered items on the next page in Your e-mail message.

1. Name of the product you give feedback of: _____

2. Serial number and software version number (if applicable) _____

3. Any comments when receiving the product. Did the package contain all required items and was it as expected?

4. For how long have you been using the product? _____

5. How helpful was the manual in using the product?

(Tick a box in the percentage scale below)

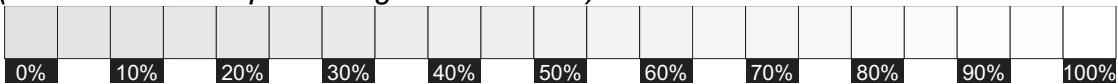

6. How well did the product suit your needs?

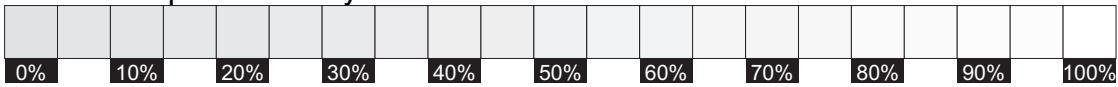

7. How satisfied are you with the product?

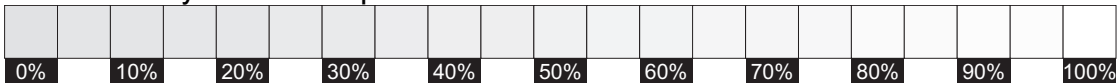

8. Did anything in the product exceed your expectations? In that case, what was it?

9. Did anything in the product disappoint you? In that case, please specify.

10. Any ideas You want to propose to Beamex so that we can improve our products, operations and/or services.

Please fill in these fields in order to receive your surprise gift.

Title & Name:

Address:

Please contact me concerning the Feedback I have given.

I want to receive more information on Beamex products.

Size (tick one)

XS S M L XL XXL

General

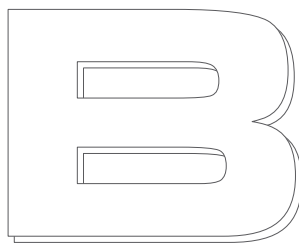
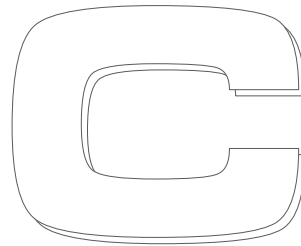
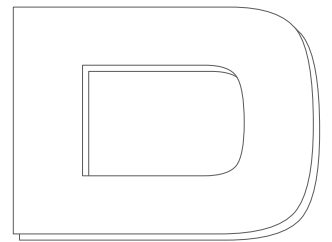

Things discussed in Part A:

- An introduction to what MC4 is and what the parts of this User Guide concentrate on.
- A general description of MC4's hardware.
- A general description of MC4's firmware.
- The modularity and options of MC4.
- Safety precautions and warnings.
- Briefly about how to service MC4.

Introduction

MC4 is a compact hand-held calibrator with an easy to use graphical user interface.

MC4 is a documenting Multifunction Calibrator with calibration capability of temperature, electrical and frequency signals. If a pressure module is installed, then it also handles pressure signals. As MC4 is a documenting calibrator, instrument data can be sent from computer to MC4 and calibration results can be uploaded from MC4 to a computer using Beamex CMX calibration software. With MC4, making automated and documented calibrations of process instruments is fast and easy.

Being a Beamex calibrator, MC4 represents the high, uncompromised quality standards evident in other Beamex calibration equipment. It is another MC calibrator you can rely on and a calibrator that completes your range of MC calibrators.

About This Manual

This User Guide is divided in four parts: A, B, C and D.

- **Part A** discusses general matters. There is also a chapter about safety.
- **Part B** describes the basic use of MC4 such as measuring signals and setting up Display Modes and Special Measurements.
- **Part C** handles configuration level usage and also offers more information concerning measurements/simulations.
- **Part D** concentrates on the calibration of instruments.

Use the information provided in the headers as a quick guide when searching for a particular subject:

- The even page header displays the current main topic (e.g. "Introduction").
- The odd page header displays the secondary level topic (e.g. "About this Manual").
- The header of each page also indicates the active part as shown in the adjacent picture (with Part B active).



Typographical Conventions

All examples of user interface texts are printed using **Arial Black**, e.g.

Field: **Trigger Level**

All front panel texts (fixed texts on MC4's cover) are printed using **Arial Narrow Bold**, e.g.

Function Key **F1**

Function and Menu keys are often referred to using both the key name in **Arial Narrow Bold** and the corresponding text (function) displayed on the screen in **Arial Black**, e.g.

Function Key **F3/Menu**

Unpacking and Inspection

At the factory each new MC4 passes a careful inspection. It should be free of scrapes and scratches and in proper operation order upon receipt. The receiver should, however, inspect the unit for any damage that may have occurred during transit. If there are signs of obvious mechanical damage, package contents are incomplete, or the instrument does not operate according to specifications, contact the purchasing sales office as soon as possible. The standard accessories are as follows:

- Calibration certificate,
- a warranty card,
- this User Guide,
- A CD-ROM with product information, USB driver etc.
- computer communication cable (USB),
- internal rechargeable NiMH batteries,
- battery eliminator/charger for the batteries,
- test leads and clips,
- a Cu-Cu adapter for millivolt measurement and
- if a pressure module (other than barometric) is included in MC4: a pressure connector adapter from G1/8" female to G 1/8" male with 60° internal cone.

For a description of available options, see **MC4 Options** on page 25.

If you have to return the instrument to the factory for any reason, use the original packing whenever possible. Include a detailed description of the reason for the return.

MC4 Hardware

General features:

- Integrated impact protectors
- A support for using the calibrator on the table
- Weight 710 ... 850 g (1.6 ... 1.9 lbs) depending on installed pressure modules.
- Operating temperature: -10 ... +50 °C (14 ... 122 °F).
0 ... +35 °C (32 ... 95 °F) when charging the batteries.
- Storage temperature: -20 ... +60 °C (-4 ... 140 °F).
Note: The stickers and the batteries may be affected when storing longer periods in extreme conditions.
- Humidity: 0 ... 80 % R.H. non condensing

More comprehensive specifications are available in Appendix 1.

Connections

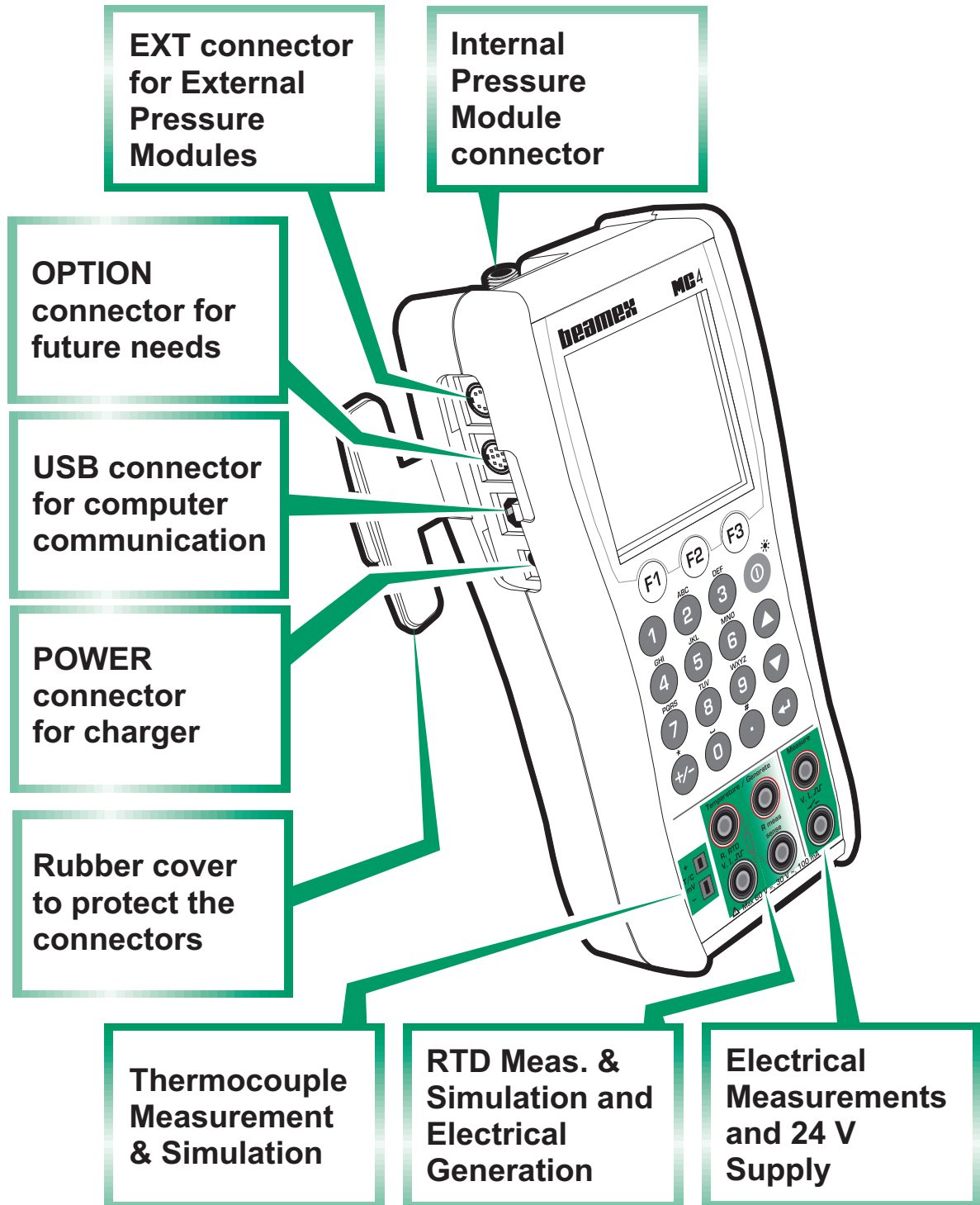

Note.

The picture above is of a MC4 with an internal pressure module. Because the pressure module is an option Your MC4 may not necessarily have it.

Pressure Modules

Internal Gauge Type Pressure Module

MC4 may include one gauge type Internal Pressure Module.

The connector for the gauge type Internal Pressure module is located in MC4's upper panel.

The allowed pressure media for gauge type internal pressure modules is inert, non-toxic, non-explosive media. Use of pressure media classified as dangerous is prohibited.

For Beamex 60° cone connector: To avoid damaging the calibrator, use hand tightening only when connecting the pressure measurement hose (max. torque 5 Nm, approx. 3.6 lbf ft). If the use of tools is required to secure the connection, apply the counterforce with a spanner on the connector body's hexagonal part.

Remember to be cautious when working with pressure and pressure modules. See also chapters **Safety** on page 27 and **Safety Precautions and Warnings** on page 28.

Internal Barometric Pressure Module

An Internal Barometric Pressure Module may also be included in MC4. The Barometric Module may be installed together with a Gauge Type Internal Pressure Module or it may be the only Internal Pressure module installed in MC4.

The Internal Barometric Module measures the barometric pressure through a connection found on the back side of MC4. Normally nothing need to be connected to the barometric pressure module's connector.

External Pressure Modules

MC4 has a connector for External Pressure Modules (EXTs). The connector is located on the left side of MC4.

If an External Pressure Module is connected or removed, MC4 notices it automatically. More of pressure measurement in part B of this manual.

Connectors on the Left Side of MC4

The left side of MC4 (front view) has four connectors as follows:

EXT	External Pressure Modules are discussed in chapter External Pressure Modules on page 7 and in Part B of this manual.
OPTION	Reserved for future needs
USB	For computer communication, e.g. when updating the firmware and sending/receiving instrument data. For USB driver information, see chapter PC Communication on page 15.
POWER	Charger connector (Battery eliminator when using dry cells)

Warning!

There is no galvanic isolation between the connectors on the left side as well as the internal pressure module connector.

Terminals

The lower part of the front panel has terminals for measuring, generating and simulating signals.

Measuring capabilities of **Measure** section:

- **Voltage**,
- **Current**,
- **Frequency**,
- **Pulse Counting** and
- **Switch** state sensing.

Measuring capabilities of **Temperature/Generate** section:

- **Low Voltage** measurement using either the Low Voltage connectors or the internal reference junction,
- **T/C** (thermocouple) measurement using either the internal reference junction or the Low Voltage connectors,
- **RTD** measurement and
- **Resistance** measurement.

Generation/simulation capabilities of **Temperature/Generate** section:

- **Low Voltage** generation using either the Low Voltage connectors or the internal reference junction,
- **T/C** simulation using either the internal reference junction or the Low Voltage connectors,
- **Current, Voltage, Frequency** and **Pulse** generation and
- **RTD** and **Resistance** simulation.

Support for Table Top Use

The support gives you a good viewing angle when MC4 is placed on a table top.

Memory

MC4 maintains data very much like personal computers. Data is saved on a solid state memory that does not need any power to maintain its state. Solid state memory is shock proof so the data is not lost when the calibrator is transported.



Also: all available storage can be used for anything that requires it (e.g. instrument data, calibration results etc.).

Display

MC4 has a backlit LCD display. The resolution of the display is 160 x 160 pixels.

The backlight is turned on or off by briefly pressing the power button. Pressing the button for a longer time shuts down MC4. More of backlight settings in part C of this manual.

To tune the contrast of the display:

- Press **F1/Contrast** when either viewing the welcome screen or the General Settings screen.
- Use the up  and down  arrow keys to change the contrast.

The changed settings are automatically saved as default settings.

Keyboard

Function Keys



The Function Keys are located below the display. The meaning of each Function Key varies depending on the situation. The lower part of the display indicates what the Function Key stands for at the moment.

Numeric Keys



The Number keys are used when entering numbers in numeric fields and letters in text fields (as in cellular phones).

Pressing the +/- key toggles the sign of the entered numeric value. In text fields, this key contains a set of symbols and Greek letters.

The Decimal key adds the decimal point to the numeric value that is currently edited. In text fields, this key contains additional symbols such as punctuation marks as well as super and subscript numbers.

Arrow Keys and Enter Key



The arrow keys are used when moving the cursor on the screen. They also have several special functions in certain situations, e.g. when tuning the contrast of the display.



The Enter key both starts and finishes the editing of all types of fields.

On/Off and Backlight Key



The On/Off key switches MC4 on and off. Press the On/Off key for about half-a-second to switch on/off. This delayed function prevents accidental on/off switching of MC4.

When pressing the On/Off key briefly, it toggles the display backlight on and off.

Batteries

MC4 supports the use of both rechargeable batteries and alkaline batteries. When using alkaline batteries, you need a Dry Battery Cartridge. MC4 automatically detects the battery type.

The alkaline batteries to be used are:

- Type: AA
- Cell Voltage: 1.5 V
- Amount: 4

The charger for rechargeable batteries operates in the following environments:

- Voltage: 100 ... 240 VAC
- Frequency: 50/60 Hz

MC4 may be used while the Battery Pack is being charged. The charger may also be used together with the Dry Battery Cartridge. Then it acts as a Battery eliminator.

The maximum operating time without recharging varies depending on the usage of the display back light. Also the usage of the 24V transmitter supply affects the maximum operating time. Even with constant maximum load, the standard rechargeable batteries should last for 6 hours. A good average operating time is 12 hours.

When using alkaline batteries, the maximum operating time also depends on the quality of the batteries. An average operating time is approximately 4 hours.

Full batteries:



Empty batteries:



The upper left corner of MC4's display shows a picture of a battery. The whiter the picture is, the more acute is the need for recharging (or changing of the alkaline batteries).

Notes.

MC4's internal clock/calendar uses a small amount of power although the calibrator is switched off. Remember to check the capacity of the batteries from time to time although MC4 is not in use.

To avoid loss of date and time, change the batteries with the charger / battery eliminator connected.

See also chapter **Capacity Indication** on page 14.

About the Charger and the Charging Procedure

When charging the batteries the battery symbol and a plug symbol alternates on the status bar. When charging is ready, only the plug symbol is shown.

If MC4 is shut off and the charger is connected, a battery status bar appears. After a while an estimate of the remaining charge time appears below the battery status bar (see leftmost picture below).

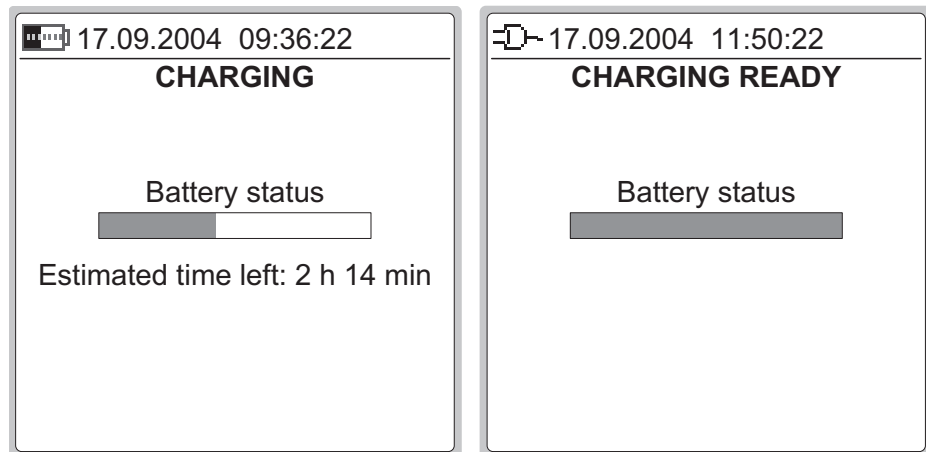

The charging time depends on calibrator's current consumption (backlight, mA sourcing etc.). With no extra load, the charging time is approx. 5 hours.

When charging while MC4 displays the charging window, MC4 beeps when the batteries are fully charged. Then the display looks like rightmost picture above.

Warnings!

USE ONLY THE CHARGER PROVIDED WITH THE CALIBRATOR.

The charger accepts input voltages from 100 to 240 VAC.

The charger should only be used indoors and the temperature should not exceed 35 °C (95 °F).

Removing/Replacing the Batteries

To remove or replace the batteries, perform the following procedure:

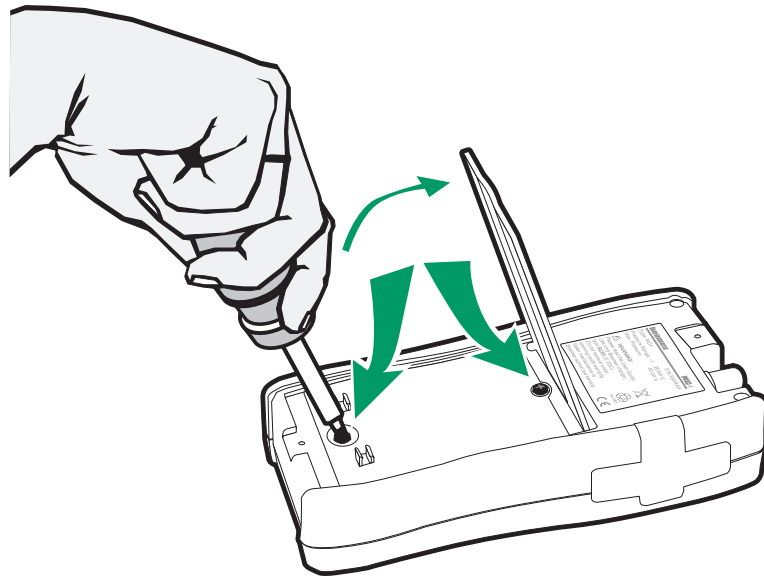

1. Turn MC4 upside down (the display facing the table top) and lift the support.
2. Unscrew the two screws holding the cover (see the picture above).
3. Bend the clip holding the battery pack connector and gently pull the connector out.
4. To replace the battery pack, click the connector of the new battery pack on its place (noting the polarity) and put the battery pack in its slot.

Note.

See also chapter **Capacity Indication** on page 14.

Capacity Indication

If you reset the calibrator or remove/replace the battery pack, "teach" the capacity of the batteries to the calibrator's charging electronics by doing as follows:

1. Fully charge the batteries (approx. 5 hours with no extra load).
2. Connect the current generation terminals to the current measurement terminals as shown in the adjacent picture.
3. Configure Window 1 to measure current with supply on. See also note below.
4. Configure Window 2 to generate (sink) 8 mA. The user interface should look as in the adjacent picture.
5. **Do not use the backlight.**
6. Let the calibrator fully discharge its batteries. This is the stage where the charging electronics "learn" the capacity of the battery pack.
7. When the calibrator shuts itself automatically, the learning is done.
8. Recharge the batteries and start using the calibrator

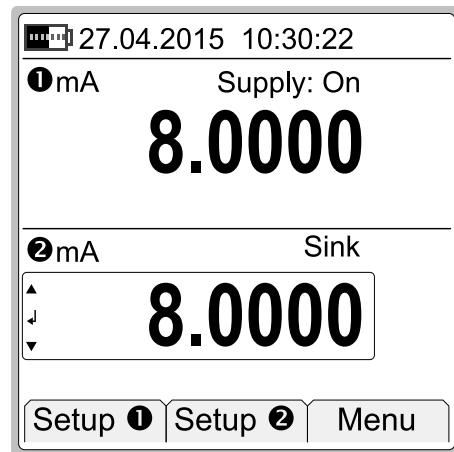
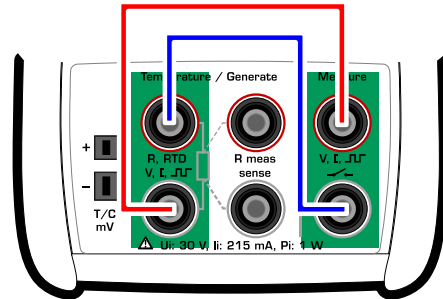

Note.

See part B for more detailed information on connections and configuring Window 1 and 2.

Hint.

If the calibrator's capacity indication has gotten mixed up, use the following method to reset the capacity indication:

Fully discharge the batteries as presented above. Then start recharging and immediately select **F3/Menu, Calibrator Adjustment** and enter **1590** as the "password". This resets the capacity indication to 0 %.

Then "teach" the capacity of the batteries using the instructions above again.

Similarly, the "password" **1599** sets the capacity to 100 %, if needed.

PC Communication with USB

The first time you connect MC4 to a computer (using the USB cable delivered with MC4), Windows' **Found New Hardware Wizard** initializes wanting to install a device driver.

The driver can be found at Beamex's web site (<http://www.beamex.com>). Look for MC2/MC2-IS/MC4 downloads. The driver is part of the software update package.

Notes.

The driver has been tested on Windows XP, Windows 2000, Windows Vista and in Windows 7, 32 and 64 bit versions.

Windows 95, 98, NT4, ME operating systems are not supported.

See also possible additional information delivered with the driver.

This procedure is needed when connecting MC2-IS for the first time to a particular USB port in a PC. After the driver is installed, communication initializes automatically, if MC2-IS is connected to the same USB port in a PC.

MC4 Firmware

MC4's firmware is saved in FLASH memory. Therefore it is relatively easy to update the firmware whenever a new version with fresh capabilities is released. See **Firmware Update** on page 32 for more information on updating the firmware in your MC4.

General Description

The following chapters briefly describe each main function.

Startup Procedure

When starting MC4 the startup procedure ends up in a welcome screen. From there it proceeds to Basic Mode and you are ready to start using the calibrator.

A more comprehensive description of the Startup Procedure is in the beginning of Part B of this manual.

Basic Mode and Higher Level Functions

In Basic Mode you can measure, generate and simulate signals. There are two separately configurable windows available.

All main functions of Basic Mode are described in part B of this manual.

Part C concentrates on higher level functions and additional information.

Instrument Database and Instrument Calibration

Instrument database and instrument calibration related information is available in Part D of this manual.

Basic Mode's User Interface

The main elements of the Basic Mode can be seen in the following picture:

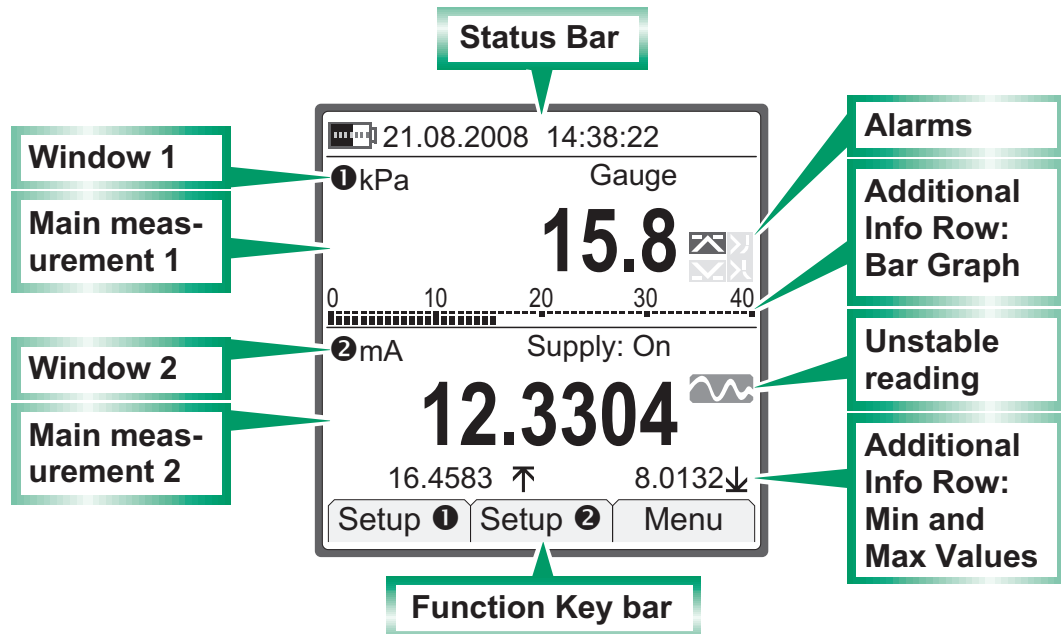

Other elements can be found in other windows. They are presented in the subsequent chapters.

The Status Bar

The Status Bar at the top of the display is divided into two sections.

The first (leftmost) section displays the charge level of the battery and a plug symbol when the charger/battery eliminator is connected. The second section displays the date and the third the time.

Windows 1 and 2

MC4 has two windows in Basic Mode. Both windows can independently be configured to display a measurement value. They can also be assigned to more data on the extra info row as seen in the previous picture.

Part of the window is reserved for alarm symbols as well as an unstable reading symbol (i.e. the measured value is not steady at the moment).

The Function Key Bar

The Function Key Bar at the bottom of the display is visible all the time. The meaning of the Function Keys varies depending on the situation. A grayed Function Key text means that the function is disabled at the moment.

Menu

The Function Keys often open menus, i.e. lists of available items.

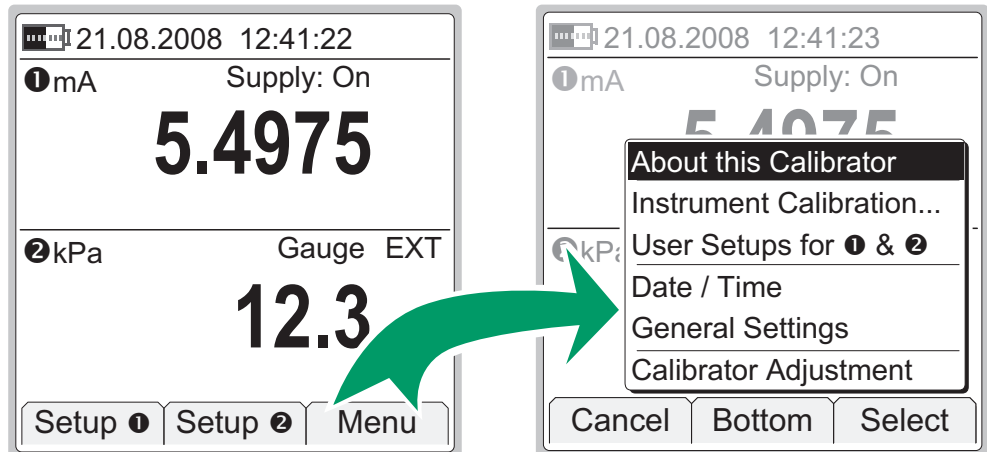

The pair of screenshots above is an example of an opening menu. This one opens from Basic Mode when F3 Function Key is pressed.

A menu with a longer list has small arrows at the top/bottom of the list to point out that the list is longer than what is shown.

Use the arrow keys (▼ and ▲) to move between menu options. The F2 Function Key helps you to scroll longer menu list. It allows you to quickly jump to the end (**Bottom**) and beginning (**Top**) depending on where in the list you are.

Select an item with the Enter key (↵) or use the F3/**Select** Function Key. Selecting a menu option results in one of the following events:

1. The menu closes and a window opens for viewing additional information or for configuring the selected task. This happens, e.g. when selecting the **About MC4** menu option in the picture above.
2. A tick is added/removed from the selected menu item. It means that the menu item is selected/deselected for a duty. This happens, e.g. when selecting which items are to be shown on the Additional Info row.
3. A sub menu opens allowing you to select one of available sub menu items.

Configuration Windows

There are several types of configuration windows. The examples below contain a selection of user editable fields.

The image shows two side-by-side screenshots of configuration windows. The left window is titled 'DATE / TIME' and contains a 'Date Format' dropdown menu set to 'dd.mm.yyyy', with fields for 'day' (10), 'month' (8), and 'year' (2004). Below it is a 'Time Format' dropdown menu set to 'hh.mm.ss 24h', with fields for 'hour (24h)' (12), 'min' (15), and 'sec' (22). An 'Ok' button is at the bottom right. The right window is titled 'ALARMS' and shows a gauge reading '0.06' for 'kPa'. It has a checked checkbox for 'Alarms Active'. Under 'Alert when the measurement', there is a checked checkbox for '>' with a value of '1.500' and an unchecked checkbox for '<' with a value of '0.100'. Under 'Alert when the rate of change', there are three buttons: 'Stop', 'Capture', and 'Ok'.

The view of the date/time configuration window contains selection lists and numeric fields.

The view of the alarms configuration window contains check boxes and numeric fields.

Descriptions of all field types are presented in the subsequent chapters.

Field Types Available for Editing Data

Use the arrow keys (▲ and ▼) to move between fields. Start and stop editing a field with the Enter key (↵).

Fields typically have three modes:

1. The field is displayed, but the cursor is **not highlighting** that particular field.
2. The cursor **is highlighting** a field.
3. The field is in **edit mode**.

All field presentations include a list of how the field looks in different states. Some fields do not exactly follow the above mentioned list of states. The differences are described where applicable.

Numeric Fields

	Numeric Field
Not highlighted:	<input style="width: 30px; height: 20px; border: 1px solid black;" type="text" value="10"/>
Highlighted:	<input style="width: 30px; height: 20px; background-color: #333; color: white; border: 1px solid black;" type="text" value="10"/>
Edit Mode:	<input style="width: 30px; height: 20px; border: 1px solid black; border-bottom: 2px solid black;" type="text" value="15"/>

Beside the Enter key (↵), all Numeric keys sets the highlighted Numeric field to edit mode. The Enter key leaves the previous number available for editing and the Numeric keys replace the old value.

During edit mode, you can use the arrow keys (▲ and ▼), the **F3/Clear** and **F2/ ←** (= backspace) Function Keys to edit the field.

Accept the new value by pressing the Enter key (↵). To discard changes, use the **F1/Cancel** Function Key. See also Part B for special features concerning numeric fields when generating a signal.

Notes.

Certain numeric fields have an extra tool for inserting a value: When the field is highlighted, an **F2/Capture** Function Key appears. This allows you to capture and save the measured value in the Numeric field.

Numeric field used for generating/simulating signals include additional editing possibilities: **Spinning** and **Manual Stepping**. More of them in part B, **page 54**.

Text Fields

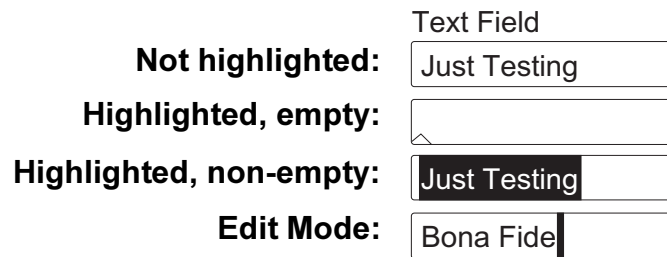

Beside the Enter key (↵), all Numeric keys set the highlighted Text field to edit mode. The Enter key leaves the previous text available for editing and the Numeric keys replace the old text.

During edit mode, you can use the arrow keys (⬆ and ⬇) and F2/ ⬅ (= backspace) Function Key to edit the field.

Use numeric keys to add characters. Adding characters is done as follows:

- First keypress opens a list of available characters with the first item highlighted.
- Repeated keypresses alter the highlighted characters.
- Press the Enter key (↵) or the **F3/Select** Function Key to select a character. Additional functionality while the list of available characters is open:
 - If no key is pressed for a certain time, the **Automatic Adding** utility selects the highlighted character (not used in the list of symbols opening from the decimal key).
 - Pressing **F3/Cancel** closes the list of available characters and no character is selected.

The **F3/Menu** Function Key allows you to do the following tasks:

- Select whether the added characters are: **Upper Case, Lower Case** or **Numbers**.
- Select whether the **Automatic Adding** of characters is: **Fast** or **Slow**.
- **Clear** the field.
- **Ok** for accepting the edited text.

Accept the new text by pressing the Enter key (↵) or use the previously mentioned menu option. To discard changes, use the **F1/Cancel** Function Key.

Selection Lists

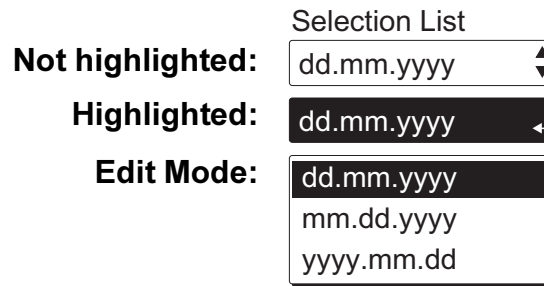

The Enter key (↵) changes a selection list to edit mode. A list of available options appear. If the list can not display all available items at the same time (not enough room), the list has small arrows at the top/bottom. This indicates that the list is longer than what is shown.

Use the arrow keys (▲ and ▼) to move between options. The F2 Function Key helps you to scroll longer menu list. It allows you to quickly jump to the end (**Bottom**) and beginning (**Top**) depending on where in the list you are.

Select one of the options with either the Enter key (↵) or the F3/**Select** Function Key. To discard changes, use the F1/**Cancel** Function Key.

Some of the selection lists have "favorites" i.e. recently selected items are moved to the top of the list. This feature is typically available in longer lists.

Hint.

To quickly jump to an option, use the Numeric keys. The first press jumps to the closest option starting with the first letter stated above the Numeric key. Repeated key presses jump to options starting with subsequent letters stated above the Numeric key.





Check Boxes

Highlighted: Check Box

Checked:

Unchecked:

A check box has no edit mode. Once it is highlighted (thicker borders), the value of the check box can be altered using one of the following possibilities:

- The Enter key () toggles the value of the check box.
- The Sign key () also toggles the value of the check box.
- The Zero key () clears the check box.
- The One key () sets the check box.

MC4 Options

MC4 includes optional hardware modules. This makes it possible to buy a calibrator with capabilities according your requirements.

Hardware Modules/Options

Internal Pressure Module (NPM)

Available gauge pressure modules:

- NPM200mC, range: ± 200 mbar (± 80 iwc)
- NPM2C, range: -1 ... +2 bar (-14.5 ... 30 psi)
- NPM20C, range: -1... +20 bar (-14.5 ... 300 psi)
- NPM160, range: 0... 160 bar (0 ... 2400 psi)

MC4 may include one of the above mentioned internal pressure modules and additionally an internal barometric module.

Optional Dry Battery Cartridge

Enables use of AA size dry batteries instead of the standard rechargeable NiMH pack accessory.

Optional Pressure T-hose

Hose set for connecting an instrument to be calibrated, a pressure source and MC4.

Optional Soft Carrying Case

MC4's soft carrying case is practical when moving between locations. The carrying case can also be used for transporting utilities, like:

- Test hoses, test leads and clips
- External Pressure Module
- A pressure pump
- Charger and its cable

The carrying case is suited for use in normal industrial environment.

Optional Connection Cable For External Pressure Modules (EXT)

Needed when connecting External Pressure Modules (EXT) to MC4.

Optional Thermocouple Mini Plugs

For connecting thermocouples to MC4's T/C, mV connector.

Other Devices

There is an increasing number of devices that can be used together with MC4. The following list includes devices that are already available (valid when this manual was printed):



- External Pressure Modules (EXT)
- Calibration hand pumps:
 - **PGV** vacuum pump,
 - **PGM** high pressure pump and
 - **PGXH** extra high pressure pump

Safety

The materials of MC4's case withstand normal industrial conditions. MC4 endures shocks with the help of the built in impact protectors

Symbols Used

The following symbols concerning electrical safety are used in MC4.

	Alternating current, AC
	Direct current, DC
	Caution! See manual for further information

Safety Precautions and Warnings

MC4 calibrator is a precision calibration tool that should be used by skilled people who have read and understood this User Guide. Working with MC4 involves the usage of pressure and/or electrical instruments. Be sure to know how to work with these instruments and how to safely connect/disconnect pressure hoses as well as electrical test leads clips, etc.

Use MC4 only if you are certain of that it can be used safely. Safe use of MC4 is no longer possible if one or more of the following cases are true:

- When the case of MC4 is evidently damaged
- When MC4 is not functioning as expected
- After prolonged storage in unfavorable conditions
- After serious damage during transport

Sometimes it is necessary to use a portable radio transceiver while working with the calibrator. To prevent calibration errors caused by the radio frequency interference, keep the radio far (at least 1 meter) from the calibrator and the circuit under calibration while sending.

General Warnings

Do not use MC4 in any other way than as described in this User Guide.

Use the MC4's battery charger in a non-hazardous indoor location only and only with Beamex MC4 calibrators. While charging, the temperature should not exceed 35 °C (95 °F). If MC4's battery charger is broken, dispose it according to local waste regulations and order a new charger from Beamex. Do not connect a broken charger to MC4.

MC4 uses a rechargeable Battery Pack or alkaline batteries. All of these battery types are considered as hazardous waste. Dispose used batteries properly according to local regulations.

Avoid short circuiting the batteries. The short circuit current may cause burns to you, damage to the device or even fire. Notice, that also new replacement batteries are shipped in charged state.

Rechargeable batteries may vent small amounts of gas during recharge. The vented gas mixture may be highly explosive, but normally it diffuses rapidly into the atmosphere. To avoid danger, use only the original charger and never recharge in a gas-tight container.

Warnings Concerning Electrical Measurement and Generation

The measurement and generation terminals of MC4 are protected against over voltage and over current as far as it has been possible without affecting the accuracy. Do not however connect signals that are above the measurement range of the selected Function.

There is no galvanic isolation between the connectors on the left side, the internal pressure module connector and the terminals of the Temperature/Generate section.

Although there is a galvanic isolation between MC4's Measure and Temperature/Generate sections, it is for functional purposes only. Do not exceed 60 VDC / 30 VAC / 100 mA between any terminal.

Maximum output voltage from MC4's terminals is below 30 V. If you, however, connect together voltages from the Measure and Temperature/Generate sections or if you connect external voltages to MC4, the resulting voltage may be high enough to be hazardous.

General Warnings Concerning Pressure Measurement

The optional pressure T-hose is rated to the maximum pressure of 20 bar at 21°C (290 psi at 70°F). Applying higher pressure can be hazardous. We recommend the use of the optional pressure hose set. When using other hoses and connectors, make sure they are high quality products that withstand the used pressure.

To avoid damaging the calibrator, use hand tightening only (max. torque 5 Nm) when connecting the pressure measurement hose to the internal pressure module. If the use of tools is required to secure the connection (typically an internal pressure module with a pressure range of 20 bar / 300 psi), apply the counterforce with a spanner on the connector body's hexagonal part.

Always depressurize the system before opening or connecting any pressure fittings or connectors. Use proper valves for venting the system. Ensure that all connections are made correctly and that the hose and the connectors are intact.

The allowed pressure media for internal pressure modules is inert, non-toxic, non-explosive media. External modules have the allowed media printed on the module's sticker. Using unsuitable pressure media may destroy the pressure module/calibrator.

External Pressure Modules: Use only the pressure media stated on the pressure module. Use of wrong type of Pressure Media may destroy the pressure module.

Never exceed the maximum pressure of a pressure module. The internal pressure module's maximum pressure is stated on calibrator's sticker. The maximum pressure of external modules is stated on module's sticker and mentioned in the Instruction Booklet that is provided with the external module.

Never plug a hose with your hands or put hands in front of a gas spray coming from a leakage. A gas bubble in the blood circulation can cause death.

Warnings Concerning High Pressure

High pressure is always dangerous. Only personnel with good experience and knowledge of high pressure liquid, air and nitrogen operations are allowed to work with the module. Read carefully all these instructions and familiarize yourself with local safety instructions for high pressure operations before starting the use.

When using gas, the system must not contain any liquid, especially if you do not know how they may react under pressure. Use of clean air or nitrogen is recommended as gaseous pressure media. Liquid pressure media should be preferred when using modules with a pressure range of 60 bar (30000 psi) or more.

If you use nitrogen, minimize the leak to the atmosphere and take care of sufficient ventilation. Close the valve of the nitrogen cylinder, when the system is not in use. Increase in the percentage of nitrogen in the ambient air may cause unconsciousness and death without warning. Read carefully the safety instructions for nitrogen and make sure that the other people in the same space are aware of the danger.

Use of liquid pressure medium is recommended with pressure measurement modules at higher pressure range. Use water or suitable hydraulic oil. Check that the used liquid is not aggressive against the materials used in the transducer or tubing. When using liquid, minimize the amount of air in the system. So you can minimize the amount of spilled liquid in case of leakage.

Do not use the same tubing with different liquids or gases.

Check what the local regulations say about construction and use of pressurized vessels. The regulations normally control construction and use of systems where the product of the pressure and volume exceeds a certain limit. The volume of this system depends on the instrument connected to it.

High pressure gas is dangerous because it can break the container and the flying splinters may cause injury. Also small leaks of gas may be dangerous because the high velocity of the leaking gas jet enables penetration through skin. If a gas bubble gets into the blood circulation, it can cause death. The leak jet is particularly penetrative, if some liquid is coming with the gas.

Disposal of Waste Electrical and Electronic Equipment

Beamex is an environmentally conscious company developing products with a view to ensure that they are easy to recycle and do not introduce hazardous materials into the environment.

In the European Union (EU) and other countries with separate collection systems, waste from electrical and electronic equipment (WEEE) is subject to regulations.

EU WEEE Directive 2002/96/EC (the WEEE Directive) requires that producers of electronic equipment are responsible for the collection, reuse, recycling and treatment of WEEE which the Producer places on the EU market after August 13, 2005. The objective of this regulation is to preserve, protect and improve the quality of the environment, protect human health, and conserve natural resources.



The symbol on the left is also printed on the product's sticker. It indicates that this product should be handed over to applicable collection point for the recycling of electrical and electronic equipment.

For more detailed information about recycling of this product, please contact your local representative or your waste disposal service.

Service

Only qualified service personnel may perform higher level maintenance for MC4. **Never open the case unless have explicit instructions from Beamex or a local representative.**

There are, however a few things that anyone using MC4 may do.

Firmware Update

The quickest way to see if a new firmware version is available is checking out Beamex's web site (<http://www.beamex.com>). Go to the "Downloads" page and see what it says about MC4 firmware versions and downloads.

All you need is a Personal Computer and the Computer communication cable that connects MC4 to one of the USB ports in your PC. For USB driver info, see chapter **PC Communication with USB** on page 15 of this manual.

Also check for possible release notes accompanying the updated file.

The Battery Charger

The charger is not intended to be serviced. When unusable it can be thrown away according to local waste disposal regulations.

Resetting MC4

Sometimes you may want to reset the calibrator. To do that, press and hold the Enter key (↵) and the On/Off key (⏻) for 5 seconds. Then press the On/Off key again.

Resetting MC4 resets the clock to midnight, January the 1st 1970. Remember to enter the correct date and time.

Recalibrating MC4

Please contact Beamex for details on recalibrating MC4.

Cleaning MC4

If MC4 needs cleaning, use cloth soaked with a mild solution of tall oil soap (pine soap). Wait a few minutes and then clean using a cloth moistened with pure water. Never use any strong detergents.

(Empty)

Startup and Basic Operation

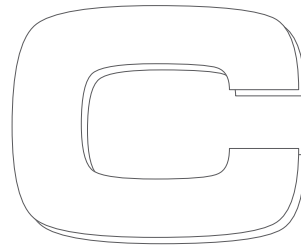
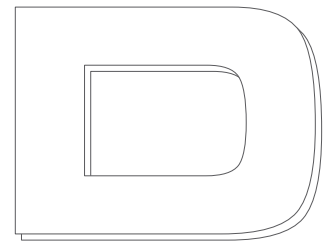

Things discussed in Part B:

- What happens during the startup procedure.
- Measuring signals.
- Generating/simulating signals.
- Presenting the utilities available in a window's Tools menu.

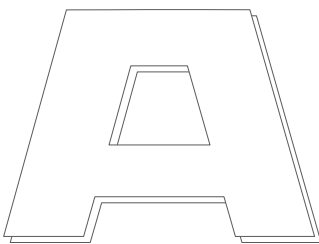

Starting MC4

Startup Procedure

When MC4 is started, a startup picture appears. After a self test, a welcome screen appears displaying some basic information of the calibrator at hand.

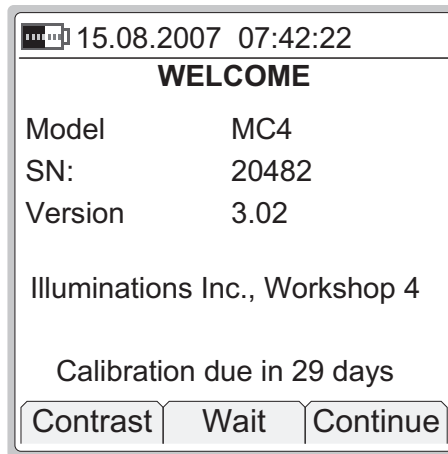

If you want to view the calibrator information for a longer period, press the **F2/Wait** Function Key. Then the calibrator information is visible until you press the **F3/Continue** Function Key.

The lowermost row displays the days until (or since) MC4's due date for recalibration. If the calibration is overdue, or in the near future, MC4 stops at the welcome screen to remind you of the need for recalibration. Otherwise it continues to Basic Mode after a while (or when you press the **F3/Continue** Function Key).

Basic Mode, Defined

All non-calibration related measurements and generations are performed in the Basic Mode. Briefly: in Basic Mode MC4 works like a high quality multimeter. When returning from MC4's higher level operations (calibration, viewing of calibration results, calibrator and user configurations), you always return to the Basic Mode.

In Basic Mode, the two available measurement/generation/simulation windows have default settings based either on factory settings or settings defined when MC4 was previously used.

The Function Keys at the bottom of the window allow you to change the settings of the two windows or open a menu for higher level operations etc.

Below is an example picture of a Basic Mode screen with the following settings.

Window ❶:

- Pressure measurement using an external pressure module.
- Minimum and maximum value display on the additional info row.
- High limit alarm in use, but not active (⚡).
- Low limit alarm in use and active (ⓧ).

Window ❷:

- Current measurement using MC4's 24 V power supply .
- Bar graph active on the on the additional info row.

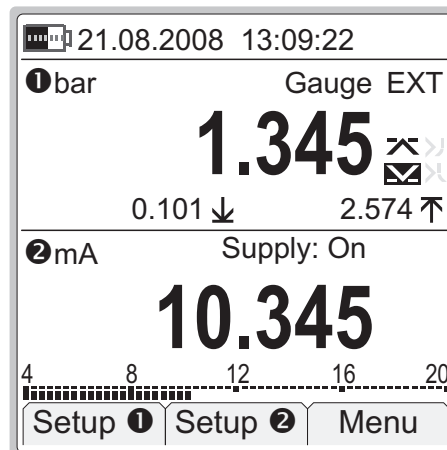

What can be done in Basic Mode

- Measure signals
- Generate signals
- Simulate signals
- Set alarm limits
- Start special measurements (min/max value etc.)
- Use the ramping function
- Use the stepping function

Next...

Measuring on page 39

Generating/Simulating on page 53

Tools Menu on page 67

Alarms on page 69

Measuring

MC4 is capable of performing the following measurement functions:

- Current measurement
- Frequency measurement
- Pressure measurement
(with an optional internal pressure module or with an external pressure module)
- Pulse counting
- Switch state sensing
- Voltage measurement
- Resistance measurement
- RTD temperature measurement
- T/C temperature measurement

To start measuring a certain quantity, configure one of the Basic State's windows (select **F1/Setup ①** or **F2/Setup ②**). Use the Enter key to open to the list of **Functions** (uppermost field in the configuration window) and select what you want to measure. All other fields refine the measurement characteristics.

When presenting measurements in this manual, the first paragraph describes the measurement followed by the **Function** setting needed to start that particular measurement.

Notes.

In this manual, MC4's measurement Functions are presented in alphabetic order. The order the Functions appear on your MC4 depends on which Functions have been used most recently.

A Function or a set of Functions using the same terminals can not be selected for several windows simultaneously. MC4 limits the list of available Functions based on Functions already in use. To free terminals, select **No Function** for appropriate window.

Measurement settings including all alarms and other special measurements may be saved and retrieved. Use the utility found in the **F3/Menu** Function Key for saving and retrieving settings. This is described in Part C of this manual.

Read the warnings found in part A of this manual

Current Measurement

MC4 supports current measurement using either MC4 as the loop power supply while at the same time measuring the current or simply measuring the current while an external power supply is used.

Function: **Current Meas., Supply On** or
Current Meas., Supply Off

Also check the **HART Compatible Loop Supply** setting if you use MC4 as the power supply. When the option is checked, MC4 adds a suitable impedance to the loop to ensure HART communication.

Make sure the polarity of your connections is correct. The following pictures present the correct connections depending on whether MC4 is used for providing loop supply or not.

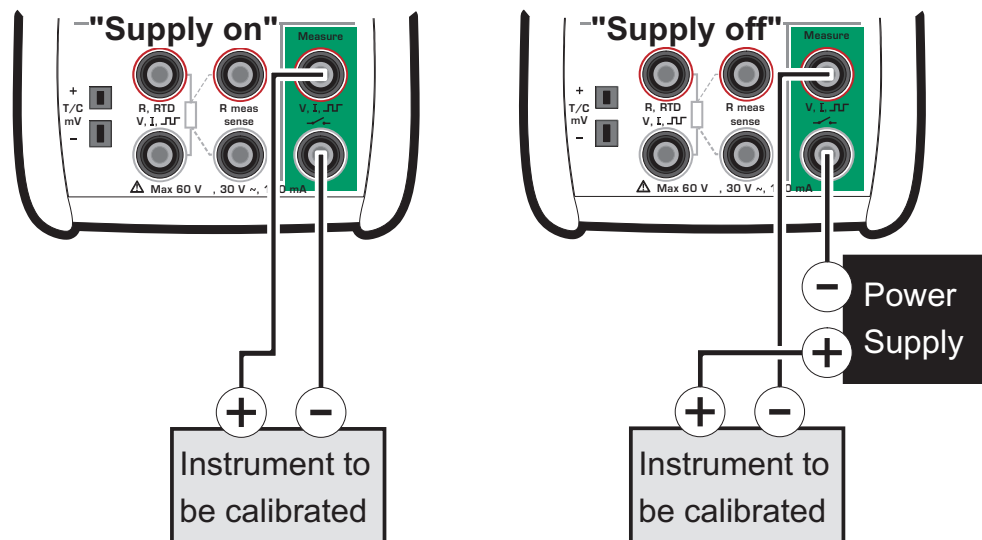

Information concerning current measurement parallel to a test diode can be found in part C, chapter **Current Measurement Parallel to a Test Diode, Connections** on page 120.

Next...

Current Generation on page 56.

Tools Menu on page 67.

Alarms on page 69.

Calibration, see Part D.

Frequency Measurement

MC4 measures frequencies between 0.0027 Hz (10 cph) to 50 kHz.

Function: **Frequency Measurement**

Also check the **Trigger Level** setting. There you can specify the trigger level and whether to use a test voltage during the frequency measurement.

The following picture displays the active terminals:

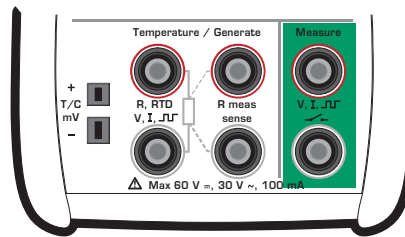

Next...

Frequency Generation on page 58

Switch State Sensing on page 48

Pulse Counting on page 46

Calibration, see Part D.

Pressure Measurement

MC4 supports the use of an internal pressure module (if installed). When connecting an external pressure module to MC4, it is automatically detected and there is a possibility to immediately put the connected external pressure module to use.

Function: **Pressure Internal**,
Pressure External or,
Internal Barometer

Also check the **Pressure Type** setting. If an internal or external barometer is present, the pressure measurement of any gauge module may also be displayed as absolute pressure. For more information concerning pressure types, see chapter **Pressure Type** on page 110.

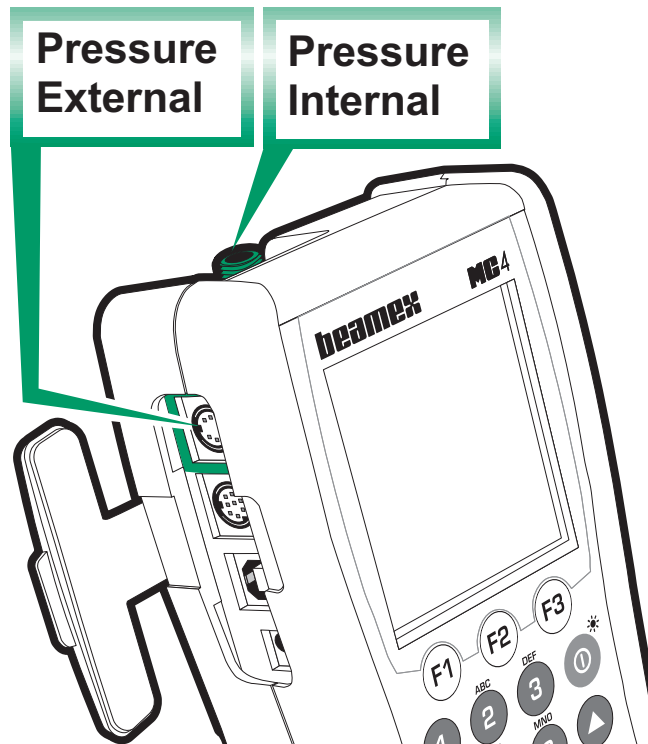

Notes.

For more information on pressure measurement and internal/external pressure modules, see chapter **Things to Consider when Measuring Pressure** on page 110.

For information on creating custom pressure units, see Part C, chapter **Custom Pressure Units** on page 108.

When using high pressure modules, you may measure pseudo absolute pressure. Open the setup window (select **F1/Setup ①** or **F2/Setup ②**), change the pressure type to absolute. Then an extra field for entering the barometric pressure appears. Enter the barometric pressure manually and press **F3/Ok**. MC4 adds the manually entered barometric pressure to the measured gauge pressure and displays the (pseudo) absolute pressure

Connecting and Disconnecting External Pressure Modules

An external pressure module may be connected and disconnected at any time. If a removed module was part of an active measurement, MC4 emits a "bleep" to inform you of the fact that the external pressure module used for pressure measurement was removed. The window where the external pressure measurement was configured reverts to "None/No Function". This happens even if the external pressure module was used as the secondary measurement in a special measurement.

External Barometric Module Specifics

If MC4 includes an internal barometric pressure module and an external barometric module is connected, the following rules apply:

- **For most cases:** When the external barometric module is connected to MC4, it supersedes the internal barometric module.
- **Exception:** If the internal barometric module is used in conjunction with a gauge module (Pressure Type is **Absolute**) and the external barometric module is connected, then MC4 continues to use the internal barometric during that measurement session.
- **Disconnecting:** When the external barometric module is removed, any measurements utilizing it are stopped. Restarting the measurement takes the (possible) internal barometric module in use.

Zeroing a Pressure Module

If the selected pressure module does not display zero gauge pressure when the applied pressure is zero, the module has to be zeroed.

Open the appropriate window setup menu (**F1/Setup ①** or **F2/Setup ②**) and select **F1/Zero Pressure**. If a secondary pressure module is active in the selected window (see **Tools Menu** on page 67), a pop-up menu will appear for choosing either to zero the primary or the secondary pressure module.

NOTE!

Zeroing a pressure module is especially important when the operating position of MC4 is changed or the location of MC4 is changed in the vertical direction. Both of the above mentioned factors affect notably on the pressure measurement modules. Measuring pressure below 100 mbar (approx. 40 iwc) should be done with a firmly mounted MC4 (e.g. placed on a table top).

Next...

Tools Menu on page 67
Alarms on page 69
Calibration, see Part D.

Pulse Counting

Function: **Pulse Counting**

Check the **Trigger Level** setting to specify the trigger level and whether to use a test voltage during the pulse counting. Also check the **Trigger Edge (Rising or Falling)** setting so it suits your need.

The following picture displays the active terminals:

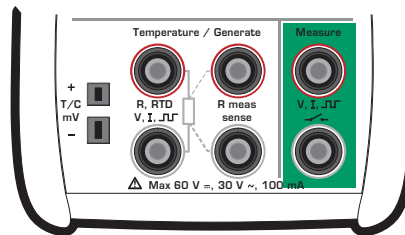

The counter may be cleared (zeroed) by selecting **F1/Setup 1** or **F2/Setup 2** (depending on which window is used for pulse counting) and **F1/Clear Pulses**.

Next...

- Pulse Generation** on page 59
- Frequency Generation** on page 58
- Frequency Measurement** on page 42
- Switch State Sensing** on page 48
- Calibration**, see Part D.

Resistance Measurement

Function: **Resistance Measurement**

The following picture displays the active terminals:

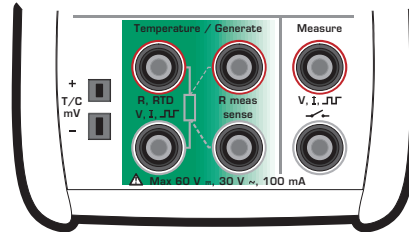

The two leftmost terminals are used in 2-wire systems. MC4 automatically checks the connection and displays the found wiring system (2-wire, 3-wire or 4-wire) in the upper right corner of the measuring window. For more information concerning wiring options, see **Resistance and RTD Measurement, Connections** on page 118.

Note.

If the measured resistance value is infinite or very high (> 4000 ohm), the text "+OVER" is displayed in the measuring window. This means that the circuit is broken or the connection is wrong. Wrong connection may also cause erroneous reading, typically too low. If necessary, use the 2-wire ohm measurement to check the wiring before final connection.

Next...

Resistance Simulation on page 60

Temperature Measurement (RTD) on page 50

Tools Menu on page 67

Alarms on page 69

Calibration, see Part D.

Switch State Sensing

MC4 is capable of detecting switch's state both when the switch is free of external potential and switches with DC voltages within the range -1 V to +30 V.

Function: **Switch**

Also check the **Trigger Level** setting. There you can specify whether to use only a trigger voltage level or do you also want MC4 to include a test voltage to detect switches with no external potential. All voltages below the trigger level are treated as a closed contact and all voltages above the trigger level are treated as an open contact.

The following picture displays the active terminals:

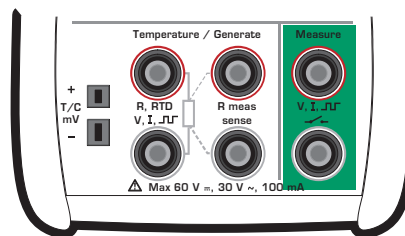

When switch state sensing is selected, the extra row info of the window with the Switch Function is capturing measurement values of the other window every time the switch changes its state. In the adjoining screen shot, the switch's current state is "open" (the big switch symbol). The last time the switch opened, the pressure was 3.058 bar and the last time the switch closed, the pressure was 1.983 bar.

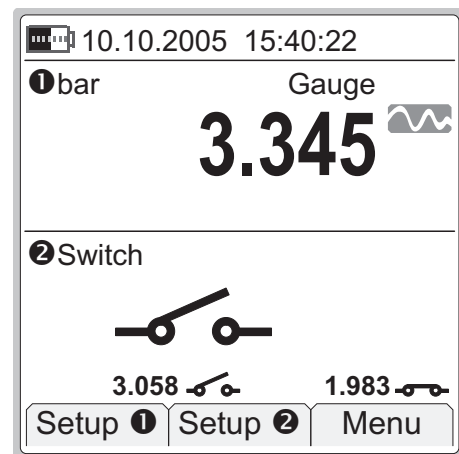

Notes.

The accuracies of the captured values depend greatly on the change rate of the switch's input signal.

Hint!

Switch state detection may also be used for binary signal detection. An open switch equals "1" or **true** and a closed switch equals "0" or **false**.

Use Switch Sound field to assign an "alarm" to a switch. Then you can use switch test for conductivity/continuity tests with no need to look at the display.

You can invert the switch's open/closed state indication using the check box available in the measurement window's setup window. This can be used to show real switch state when switch state sensing is connected to relay coil instead of relay contacts.

Next...

Tools Menu on page 67

Alarms on page 69

Calibration, see Part D.

Temperature Measurement (RTD)

Function: **RTD Sensor Measurement**

Also check the **Sensor** setting. Make sure you select the same sensor type than what is connected to MC4. Otherwise your measurement results are unreliable. For information on creating custom Platinum Resistance Temperature (PRT) type RTD sensors, see Part C, chapter Custom PRT Sensors on page 106.

The picture below displays the active terminals.

The two leftmost terminals are used in 2-wire systems. MC4 automatically checks the connection and displays the found wiring system (2-wire, 3-wire or 4-wire) in the upper right corner of the measuring window.

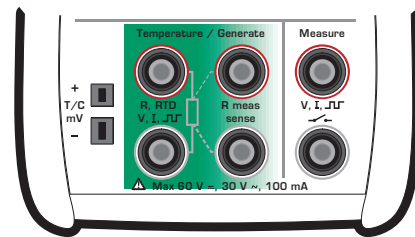

For more information concerning wiring options, see **Resistance and RTD Measurement, Connections** on page 118.

By default the additional info row at the bottom of the window displays the measured RTD resistance. More of additional info row on page 90.

Note.

If the measured resistance value is infinite or very high (> 4000 ohm), the text "+OVER" is displayed in the measuring window. This means that the circuit is broken or the connection is wrong. Wrong connection may also cause erroneous reading, typically too low. If necessary, use the 2-wire ohm measurement to check the wiring before final connection.

Next...

- RTD Sensor Simulation** on page 61
- Resistance Simulation** on page 60
- Temperature Measurement (Thermocouple)** on page 51
- Resistance Measurement** on page 47
- Tools Menu** on page 67
- Alarms** on page 69
- Calibration**, see Part D.

Temperature Measurement (Thermocouple)

Function: **T/C Sensor Measurement**

Make sure a **temperature unit** is selected from the **Unit** list. Otherwise the measurement displays voltages, not temperatures.

Check the **Sensor** setting. Make sure you select the same sensor type than what is connected to MC4. Otherwise your measurement results are unreliable.

Also select a suitable Reference Junction compensation method from the **RJ Mode** list. Wrong reference junction setting results in useless measurement results.

Additional information about Reference Junction compensation methods can be found in chapters **Internal Reference Junction** on page 113 and **External Reference Junction** on page 114.

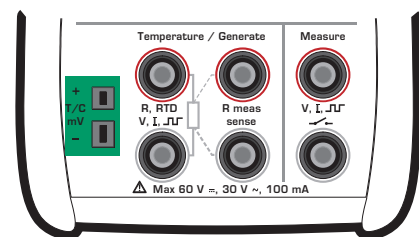

The picture above displays the active terminals.

By default the additional info row at the bottom of the window displays either the thermovoltage corresponding to Reference Junction temperature 0°C (when **Unit** field is set to temperature) or the thermovoltage with Reference Junction compensation taken into account (when **Unit** field is set to "Voltage + RJ"). In both cases also the Reference Junction temperature is shown. More of additional info row on page 90.

Warning!

If you connect an RTD sensor to the RTD connectors, there is no galvanic isolation between the thermocouple and the RTD sensor.

Next...

Thermocouple Simulation on page 63

Temperature Measurement (RTD) on page 50

Voltage Measurement on page 52

Tools Menu on page 67

Alarms on page 69

Calibration, see Part D.

Problems with thermovoltage measurement? See **Error situations** on page 117.

Voltage Measurement

MC4 has two voltage measurement ranges:

Measurement range: 1 to +60 VDC

Function: **Voltage Measurement**

The active terminals for this measurement range are highlighted in the adjacent picture.

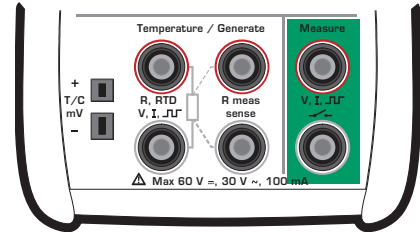

Measurement range: -25 to 150 mVDC

Function: **Low-Voltage Measurement**

The active terminals for this measurement range are highlighted in the adjacent picture.

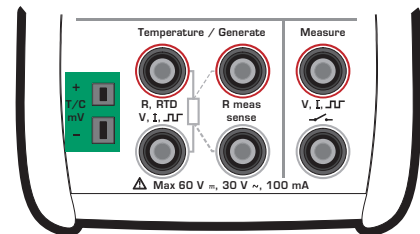

Warning!
Do not apply hazardous voltages to MC4's terminals.

Next...

- Voltage Generation** on page 65.
- Temperature Measurement (Thermocouple)** on page 51.
- Tools Menu** on page 67.
- Alarms** on page 69.
- Calibration**, see Part D.

Generating/Simulating

MC4 is capable to perform the following generation/simulation Functions:

- Current generation (source or sink)
- Frequency generation
- Pulse generation
- Resistance simulation
- RTD sensor simulation
- Thermocouple simulation
- Voltage generation

To start generating/simulating a certain quantity, configure one of the Basic State's windows (select **F1/Setup ①** or **F2/Setup ②**). Use the Enter key to open to the list of **Functions** (uppermost field in the configuration window) and select what you want to generate/simulate. All other fields refine the generation/simulation characteristics.

When presenting generations/simulations in this manual, the first paragraph describes the measurement followed by the **Function** setting needed to start that particular generation/simulation.

Notes.

In this manual, MC4's generation/simulation Functions are presented in alphabetic order. The order the Functions appear on your MC4 depends on which Functions have been used most recently.

A Function or a set of Functions using the same terminals can not be selected for several windows simultaneously. MC4 limits the list of available Functions based on Functions already in use. To free terminals, select **No Function** for appropriate window.

Read the warnings found in part A of this manual.

Changing the Generated/Simulated Value

The simplest way of changing a generated/simulated value is entering a new value using the numeric keys. Finish entering the new value by pressing the Enter (↵) key.

When entering the value, the Function Keys allow you to clear the value (F3), remove a character to the left of the cursor (F2) or cancel the entering of a new value (F1).

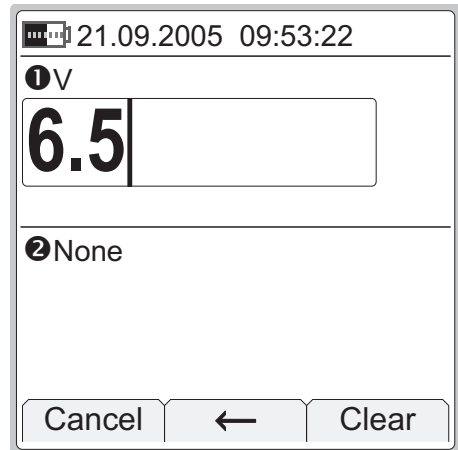

Spinning and Manual Stepping

Spinning and Manual Stepping are two easily available methods for changing the generated/simulated value.

To start **Spinning**, press the Enter (↵) key when generating/simulating and viewing the Basic Mode windows. Then one of the generation/simulation digits is inverted.

To spin the inverted digit, use the up and down arrow keys (▲ ▼). To change the digit to be spun, press either (F1) or (F3) Function Key.

To stop spinning, press the Enter (↵) key.



Manual Stepping is an additional functionality available while Spinning.

To start Manual Stepping, you first need to start the Spinning utility and then press the **F2/Step** Function Key.

To step through the defined steps, use the up and down arrow keys (▲ ▼). To toggle between the minimum and maximum value, press the (F2) Function Key.

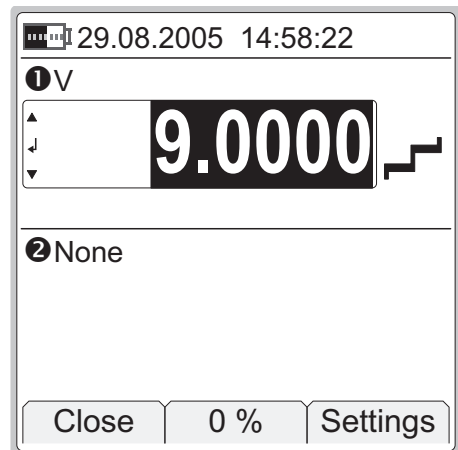

Function Key F3 opens a **Manual Step** configuration window. Its functionality is described in chapter **Manual Stepping** on page 78.

To stop Stepping and return to Spinning, press the Enter (↵) key. To stop Stepping and return to Basic Mode, press the **F1/Close** Function Key.

Notes.

You cannot exceed the minimum/maximum limits of a Function when Spinning/Stepping.

The spinned/stepped value follows the resolution properties of the generated/simulated Function.

MC4 remembers the Manual Step configuration settings for each generation/simulation Function.

Current Generation

MC4 is able to generate current both in source and sink mode. In source mode MC4 provides the supply power to the loop. In sink mode an external power supply is used and MC4 controls the current flow.

Function: **Current Source or Sink**

The connection of the current loop varies depending on the setting of the **External Supply, Sink Current (reverse polarity)** check box. See the following pictures.

Source mode:

External Supply, Sink Current (reverse polarity)

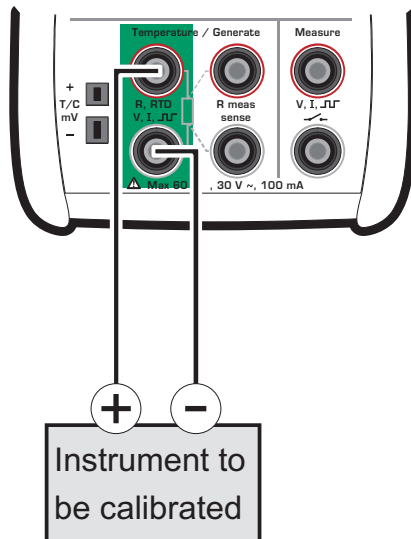

Sink mode:

External Supply, Sink Current (reverse polarity)

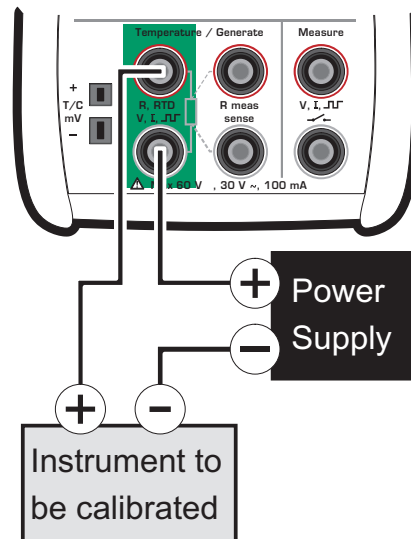

Note.

If the loop resistance of the external circuit is too high or infinite, the message "**Overload**" is displayed until the load is reasonable.

Warnings!

Make sure that you don't exceed the maximum current allowed by the instrument under test.

If you open the current generation loop, MC4 tries to maintain the current by increasing the output voltage. If you then close the loop again, the current is first too high, but returns quickly to the correct level. If this current peak could damage the components of the loop, make sure that the loop will not open or protect it against overcurrent. For the same reason, always enter 0 mA output before connecting the loop.

Next...

Current Measurement on page 41.

Tools Menu on page 67.

Stepping on page 73

Ramping on page 76.

Calibration, see Part D.

Frequency Generation

The generated frequency is either a positive or an amplitude symmetric square wave.

Function: **Frequency Generation**

Check the **Waveform** setting. The percentage value is the **Duty Cycle** setting (the ratio of the output high time to the total cycle time). Also check the **Amplitude** setting.

The adjacent picture displays the active terminals:

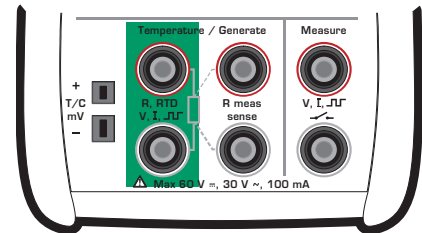

Note.

Due to technical reasons, the entered Duty Cycle setting is not always realized. This happens with relatively high and low frequencies. The true Duty Cycle percentage is shown in the appropriate Basic Mode window.

See **Appendix 1, Technical Data** for more specific info of Duty Cycle limitations.

Next...

- Pulse Generation** on page 59.
- Frequency Measurement** on page 42.
- Tools Menu** on page 67.
- Stepping** on page 73
- Ramping** on page 76.
- Calibration**, see Part D.

Pulse Generation

The generated pulses are either positive or amplitude symmetric square waves.

Function: **Pulse Generation**

The Repetition Frequency (Hz) setting defines the frequency to be used when generating the pulses.

The **Waveform** and **Amplitude** settings are similar to the settings found in **Frequency Generation** on page 58.

The adjacent picture displays the active terminals:

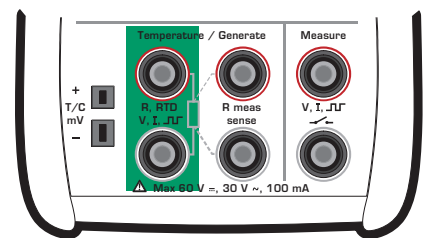

In the Basic Mode window:

Enter the amount of pulses MC4 should generate. The pulse generation starts immediately after the amount is entered.

By default the additional info row at the bottom of the window displays pulses done and pulses left (icons: ↗ and ↘ respectively). More of additional info row on page 90.

Note.

Due to technical reasons, the entered Duty Cycle setting is not always realized. This happens with relatively high and low frequencies. The true Duty Cycle percentage is shown in the appropriate Basic Mode window.

See **Appendix 1, Technical Data** for more specific info of Duty Cycle limitations.

Next...

Frequency Generation on page 58.

Pulse Counting on page 46.

Tools Menu on page 67.

Stepping on page 73

Ramping on page 76.

Calibration, see Part D.

Resistance Simulation

In resistance simulation MC4 mimics a resistor. The instrument under test generates the current for the resistance measurement. MC4 controls the voltage across its terminals so that the resistance (voltage to current ratio) corresponds to the resistance.

Function: **Resistance Simulation**

The correct resistance value is between the resistance simulation terminals of the calibrator. Use of 2-, 3- or 4-wire connection is up to the receiver instrument. Use only the two leftmost R, RTD terminals with every wiring option. Connect the possible third and fourth wire according to the requirements of the connected instrument, but use only the two leftmost R, RTD terminals.

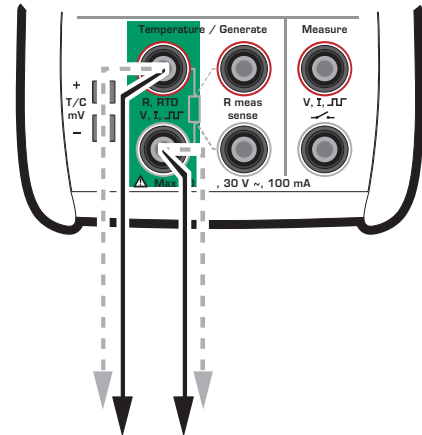

Notes.

In resistance simulation MC4 monitors the resistance measurement current. If the current is too high, it cannot simulate the right resistance value. In that case it shows the message "**High Cur**".

Accurate operation of the simulation electronics requires that the current supplied by the instrument under test does not vary rapidly. The simulation result is not accurate if the instrument under test uses AC current. If the instrument under test uses pulsed measurement current, it should wait a few milliseconds before starting the measurement after setting the current.

Next...

- Resistance Measurement** on page 47.
- RTD Sensor Simulation** on page 61.
- Tools Menu** on page 67.
- Stepping** on page 73
- Ramping** on page 76.
- Calibration**, see Part D.

RTD Sensor Simulation

In RTD sensor simulation MC4 mimics an RTD. The instrument under test generates the current for the RTD measurement. MC4 controls the voltage across its terminals so that the resistance (voltage to current ratio) corresponds to the simulated temperature.

Function: **RTD Sensor Simulation**

Also check the **Sensor** setting. Make sure you select the same sensor type than the connected instrument requires. Otherwise your simulation is useless. For information on creating custom Platinum Resistance Temperature (PRT) type RTD sensors, see Part C, chapter **Custom PRT Sensors** on page 106.

The correct resistance value is between the resistance simulation terminals of the calibrator. Use of 2-, 3- or 4-wire connection is up to the receiver instrument. Use only the two leftmost R, RTD terminals with every wiring option. Connect the possible third and fourth wire according to the requirements of the connected instrument, but use only the two leftmost R, RTD terminals.

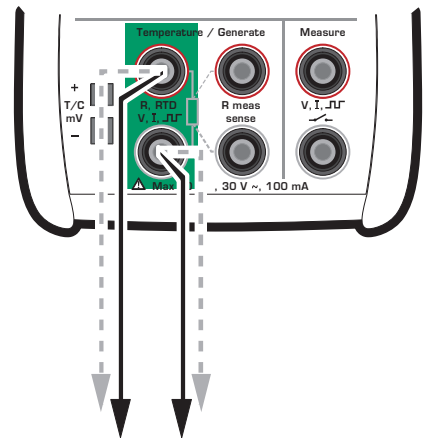

By default the additional info row at the bottom of the window displays the resistance MC4 is simulating while performing RTD simulation. More of additional info row on page 90.

Notes.

In RTD simulation MC4 monitors the resistance measurement current. If the current is too high, it cannot simulate the right resistance value. In that case it shows the message "**High Cur**".

Accurate operation of the simulation electronics requires that the current supplied by the instrument under test does not vary rapidly. The simulation result is not accurate if the instrument under test uses AC current. If the instrument under test uses pulsed measurement current, it should wait a few milliseconds before starting the measurement after setting the current.

Next...

Temperature Measurement (RTD) on page 50.

Thermocouple Simulation on page 63.

Resistance Simulation on page 60.

Tools Menu on page 67.

Stepping on page 73

Ramping on page 76.

Calibration, see Part D.

Thermocouple Simulation

In thermocouple simulation the original thermocouple is disconnected from the instrument under test and replaced with MC4. MC4 mimics a thermocouple at given temperatures. To the instrument under test MC4 appears as a thermocouple at the given temperature.

Function: **T/C Sensor Simulation**

Check the **Sensor** setting. Make sure you select the same sensor type than what is required by the instrument under test. Otherwise your measurement results are unreliable.

Also select a suitable Reference Junction compensation method from the **RJ Mode** list. Wrong reference junction setting results in useless measurement results. Additional information about Reference Junction compensation methods can be found in chapters **Internal Reference Junction** on page 113 and **External Reference Junction** on page 114.

The adjacent picture displays the active terminals:

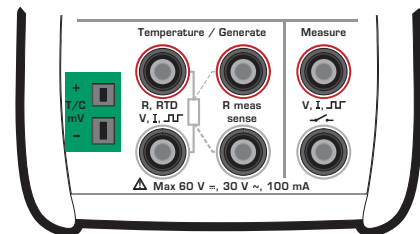

By default the additional info row at the bottom of the window displays either the thermovoltage corresponding to Reference Junction temperature 0°C (when **Unit** field is set to temperature) or the thermovoltage with Reference Junction compensation taken into account (when **Unit** field is set to "Voltage + RJ"). In both cases also the Reference Junction temperature is shown. More of additional info row on page 90.

Notes.

If the resistance of the external circuit in thermocouple simulation is very low (obvious short circuit), the message "**Overload**" is displayed until the load is reasonable.

If the thermocouple to be simulated is not available MC4's sensor list, select one of the "**Voltage + Reference Junction**" units and convert from temperature to millivolts manually. Also select a thermocouple type from the **Sensor** list that approximately matches your sensor (in used Reference Junction range). This allows MC4 to perform Reference Junction compensation as accurately as

possible. In this situation, the accuracy depends on the similarity of the selected sensor in MC4 and the used sensor.

Wire-wound thermocouple temperature indicators and recorders are calibrated with known loop resistance, commonly ten or twenty ohms. The required resistance of the conductors is usually marked on the device. When calibrating such a device, tune the loop resistance to the nominal value with an additional resistor.

Use MC4's 2-wire resistance measurement to tune the loop resistance of a wire wound device. Short circuit the measuring device for the time of resistance measurement. The resistance measurement may damage the device, if you do not install the short circuit. For more information on resistance measurement, see chapter **Resistance Measurement** on page 47.

Warnings!

If you short circuit the thermocouple simulation output, MC4 tries to maintain the voltage by increasing the output current. If you then open the output again, the voltage is first too high, but returns quickly to the correct level. If this voltage peak could damage the components of the circuit, make sure that the circuit can not be shorted or protect the circuit against overvoltage. For the same reason, always enter 0°C output before connecting the circuit.

If you connect an RTD sensor to the R, RTD connectors, there is no galvanic isolation between the thermocouple and the RTD sensor.

Next...

Temperature Measurement (Thermocouple) on page 51.

RTD Sensor Simulation on page 61.

Tools Menu on page 67.

Stepping on page 73

Ramping on page 76.

Calibration, see Part D.

Problems with thermovoltage simulation? See Error situations on **page 117**.

Voltage Generation

MC4 has two voltage generation ranges as presented here.

Generation range: -3 to 12 V

Function: **Voltage Generation**

The active terminals for this generation range are highlighted in the adjacent picture.

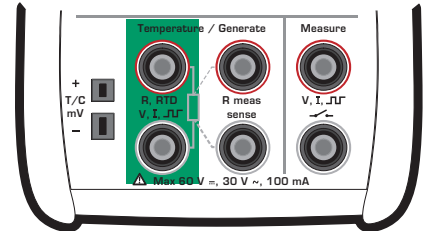

Generation range: -25 to 150 mV

Function: **Low-Voltage Generation**

The active terminals for this generation range are highlighted in the adjacent picture.

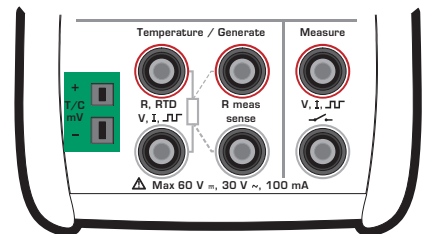

Warning!

If you short circuit the voltage output, MC4 tries to maintain the voltage by increasing the output current. If you then remove the short circuit, the voltage is first too high, but returns quickly to the correct level. If this voltage peak could damage the components of the circuit, make sure that the circuit can not be shorted or protect the circuit against over voltage. For the same reason, always enter 0 V output before connecting the circuit.

Next...

Voltage Measurement on page 52.

Thermocouple Simulation on page 63.

Tools Menu on page 67.

Stepping on page 73

Ramping on page 76.

Calibration, see Part D.

Manually Keyed Values

MC4 supports the use of manually entered values. They are mainly of use when calibrating instruments (see part D), but they may also be used in Basic Mode. The following example presents one use of manually entered values:

This suits instruments that have an input signal not supported by MC4, but the output can be measured by MC4. Actually, the input and output may be interchanged too as long as the one of the signals is measured and the other is entered manually.

Window ❶ settings:

Function: **Manually Keyed Value**

Window ❷ settings, e.g.:

Function: **Current Meas., Supply On** or
Current Meas., Supply Off

Open the Tools menu for window ❷. Select **Display Mode / Specials**. Choose one of the available error calculation modes. More of error calculations in chapter **Display Mode and Special Measurements** on page 81. Enter the input and output ranges in the opened window.

Connect the instrument's current output (or whatever measurement you chose for window ❷) to MC4 and manually enter the value of the other signal to window ❶. Then you will be able to view the error of the instrument's input/output relation.

Note.

MC4 deduces the resolution for the manually keyed value based on entered numbers. To ensure valid resolution, enter e.g. trailing zeros accordingly.

Tools Menu

MC4's Basic Mode windows have utilities that add extra features to your measurements/generation/simulations. They are available in a window's **Tools** menu. The contents of the **Tools** menu varies depending on which Function is selected. This is because measurement Functions require different tools than generation/simulation Functions.

Tools menu for a measurement Function:

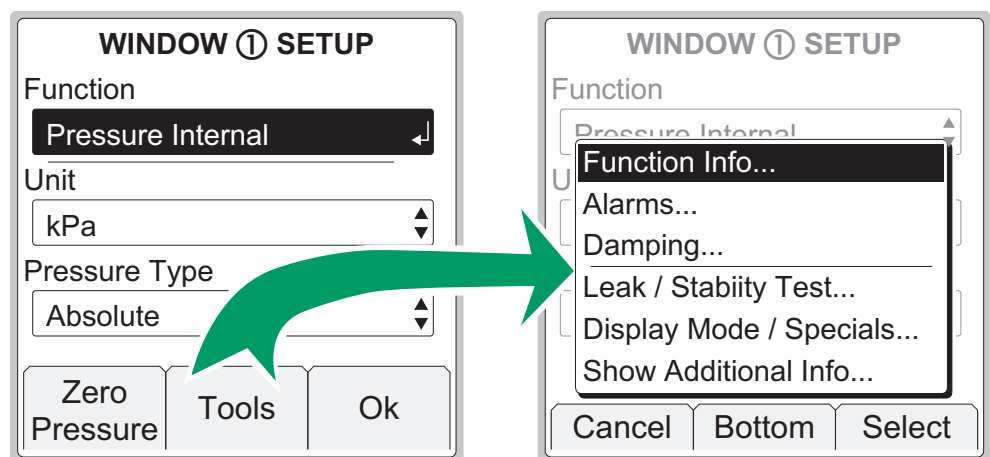

Tools menu for a generation/simulation Function:

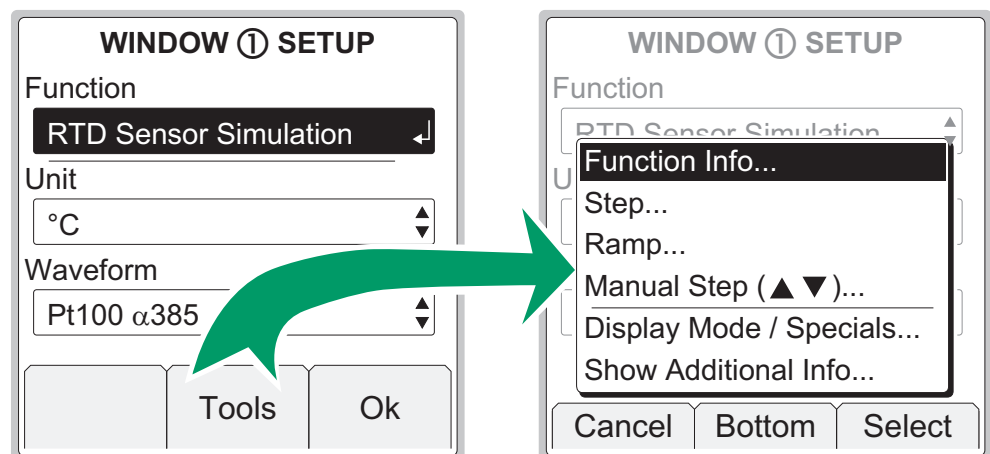

The following subchapters present each utility available in the **Tools** menu.

Function Info

Function Info option is always available in the **Tools** menu.

This option is "enhancing your measurement" by presenting some useful information of the selected quantity, e.g. the measurement range and calibration info. Function Info is divided into two pages. Use **F2/More** Function Key to move from page to page.

To see Function Info, enter the following menu commands: **F1/Setup ①** or **F2/Setup ②** (depending on which window you want to view Function Info for), **F2/Tools** and **Function Info** from the opened menu.

Alarms

Each main measurement in a window may have alarm limit settings. MC4 supports "higher than", "lower than", "high rate" and "low rate" alarms.

To set the alarm limits, enter the following menu commands: **F1/Setup ①** or **F2/Setup ②** (depending on which window you want to configure alarms to), **F2/Tools** and **Alarms** from the opened menu.

Make sure the **Alarms Active** field is checked. Then the other settings are available. Table of alarm symbols used:

⋈	High alarm limit
⋇	Low alarm limit
⋉	High change rate alarm limit
⋈	Low change rate alarm limit

Individual alarm limit values may also be activated/deactivated using the check box preceding the alarm limit value. The alarms chosen for use are shown in the measurement window using the same symbols as in the table above.

When an alarm limit is exceeded, MC4 emits an audible alarm and the alarm symbol is shown with inverted colors. To acknowledge the alarm, open the window's setup window and from here the **Tools** menu. Just below the menu's Alarm option is an item that is shown only when alarms are activated: Acknowledge this Alarm. The active alarm limit is inverted in the measurement window as long as the alarm limit is exceeded.

Note.

Rate alarm limits are not "symmetrical". E.g. high rate alarm 0.5 bar/min emits an alarm when the pressure increases faster than the limit but does not emit an alarm when the pressure decreases faster than -0.5 bar/min.

Hint.

If you want to set an alarm that utilizes the change rate alarm limit but don't know which limit value to use, display the change rate on the additional info row (see chapter **Display Mode and Special Measurements** on page 81). Observe what happens to the change rate during the event that needs an alarm. Then set the change rate alarm limit accordingly.

Acknowledging Alarms

When an alarm is active, the Tools menu of the window with the active alarm includes an option to acknowledge alarms.

Resetting Alarms and Alarm Limits

To stop using alarm limits, uncheck the **Alarms Active** field.

To stop using and clear all alarm limits, select another Function or reselect the same Function.

Damping

Damping is useful when a measurement signal contains unwanted noise. MC4 includes a set of damping tools.

To set the damping value, enter the following menu commands: **F1/Setup ①** or **F2/Setup ②** (depending on which window you want to configure damping to), **F2/Tools** and **Damping** from the opened menu. The damping settings apply to all main and secondary measurements active in the window when damping was started.

About the filtering options:

Average filters the data using the average of recent measurements.

Adaptive average uses the measurement's change rate to choose the amount of recent measurements used in the average calculation.

The next group of options are 1st order digital filters with a damping time as stated in their names.

Leak/Stability Test

Leak/stability test is a tool for testing the leak or stability of, e.g. a pressure measurement system. Generally: the test tells you both the absolute and the average change per minute of any measurement during the test period.

To open the test window, enter the following menu commands: **F1/Setup ①** or **F2/Setup ②** (depending on which window you want to configure the test to), **F2/Tools** and **Leak / Stability Test** from the opened menu.

See the leftmost picture below to see how the test window appears. The window where the test was invoked in is moved to top and enlarged to include the test data and the other window is minimized showing only the essential measurement data. Any data selected to be shown on the additional info row is temporarily hidden.

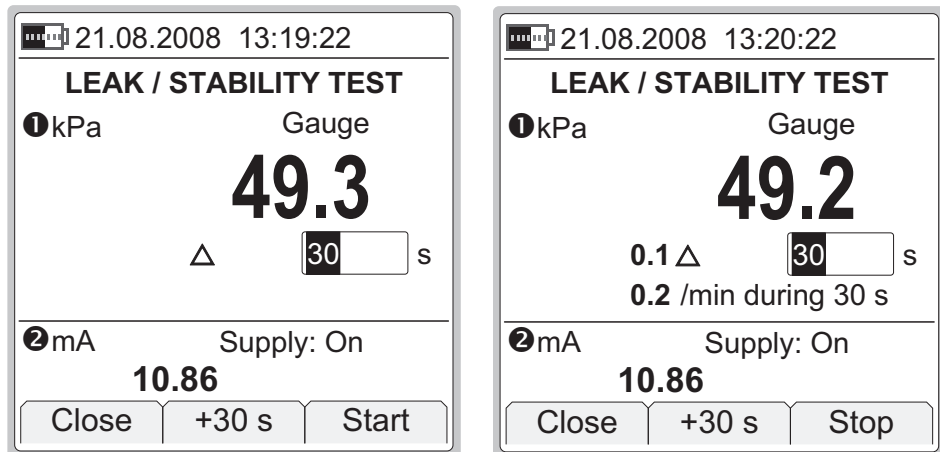

To start the test, first check the test time to be used. Either accept the default value or enter another time period in seconds. Entering zero as the test time means the test will continue until manually stopped. Select **F1/Start** and see how the test advances.

The rightmost picture above is an example of an MC4 display during a test. The absolute decrease is shown beside the triangle and the average decrease per minute below.

Notes.

You may increase the test time in 30 second steps using the **F2/+30 s** Function Key. This can be done both before the test is started and also while the test is in progress.

MC4 uses numbers that have more decimals than are available on the display. In some cases these extra digits may cause rounding that differs from values that are shown on display. Notable differences between shown and manually calculated values usually mean that MC4's accuracy is not suitable for the given task.

If applicable, disable MC4's auto-off functionality during the test. If the test lasts longer than the auto-off delay, MC4 is shut down while the test is still incomplete.

An external pressure module (EXT) connected to MC4 during a leak/stability test cannot be taken into use in the window where the leak/stability test is under progress.

Hint.

If you have a pressure transmitter connected to a pressure measurement system and you want to check the pressure decrease without altering the pressure connections, do as follows:
Connect the electrical output of the pressure transmitter to MC4. Use MC4's scaling utility to scale the output signal back to pressure units. Start the leak/stability test for the scaled measurement and there you can see the leak in pressure units. More info on scaling in chapter **Scaling** on page 86.

Stepping

Stepping utility is one of three tools allowing you to create generation/simulation signals that vary with time. This one could be called "automatic stepping" since one of the other tools is a manual stepping utility.

Other similar tools:

Ramping on page 76

Manual Stepping on page 78.

To open the stepping configuration window, enter the following menu commands: **F1/Setup ①** or **F2/Setup ②** (depending on which window you want to configure the stepping to), **F2/Tools** and **Step** from the opened menu.

The leftmost picture below shows the configuration window and the rightmost picture the stepping utility in use.

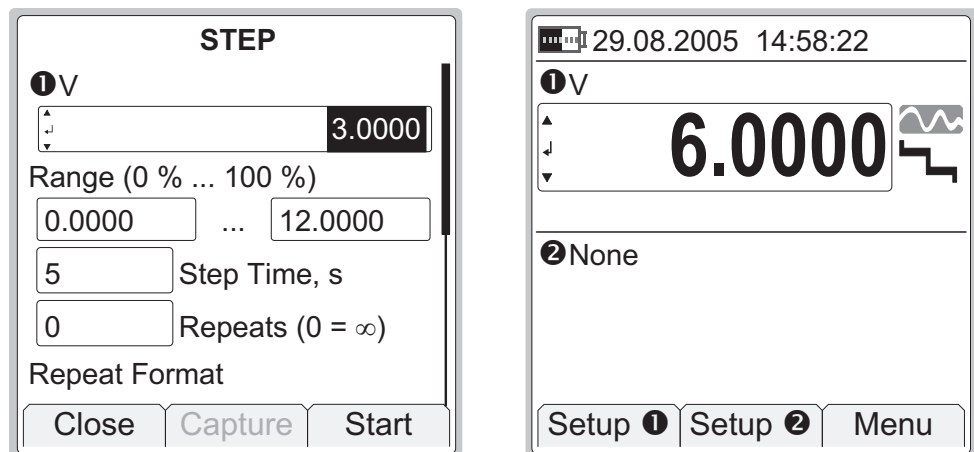

Start stepping by selecting the **F3/Start** Function Key in the configuration window. To stop a stepping that is in progress, open the stepping configuration window and press **F1/Stop Step** Function Key.

When stepping is ready, or stopped, you may restart it as follows: **F1/Setup ①** or **F2/Setup ②** (depending on which window you want to configure the stepping to), **F1/Start Step**. This possibility is available until a new Function is selected for the window where stepping was used or MC4 is shut down.

The following table presents the fields of the configuration window.

FIELD	DESCRIPTION/OPTIONS
Range[*]	The minimum and maximum value for the stepping range.
Step Time	Enter the time for a single step. Use only full seconds, no decimals.
Repeats	Defines how many times the steps are repeated. Value "zero" equals continuous stepping.
Repeat Format	How the stepping should be done. Available options: Up / Down Down / Up Up Down
Step Definition	<p>Defines how the stepping is done Available options (with no custom sets):</p> <p>By: 'Step Size' By: 'Number of Steps' 3: 50 % 5: 25 % 6: 20% 11: 10 % 0%>10>25>50>75>90>100 0%>2>4>50>96>98>100 0%>5>40>100 -2%>0>2>4>50>96>98>100>102 Create New...</p> <p>The two first options require additional data that is entered in the two following fields.</p> <p>The group of sets starting with a number and colon are sets with fixed step sizes. The first number is the amount of step levels and the percentage value is the step size.</p> <p>The group of sets starting with a number and percentage symbol are sets with varying step sizes (suitable for, e.g. valve tests). Each number is a step level. The last item in the list allows you to make your own custom step definition. Custom steps are presented in chapter Custom Test Point Sets on page 101.</p> <p style="text-align: right;"><i>Continues on next page...</i></p>

FIELD <i>(cont.)</i>	DESCRIPTION/OPTIONS
Step Size	Active only if Step Definition field is set to "By: 'Step Size'". If applicable, set the fixed step size here.
Number of Steps	Active only if Step Definition field is set to "By: 'Number of Steps'". If applicable, set the number of steps here.
Transfer Function	<p>Defines the input/output correlation. Available options:</p> <ul style="list-style-type: none"> Linear \sqrt{x} $\sqrt{x^3}$ $\sqrt{x^5}$ x2 Create New... <p>The last item in the list allows you to make your own custom Transfer Function. Custom Transfer Functions are presented in chapter Custom Transfer Functions on page 103.</p>

***)Warning!**

Do not configure the range settings so that they exceed the allowed input range of the connected instrument. MC4 determines the limits of the range settings based on the selected quantity and port, not the connected instrument.

Ramping

Ramping utility is one of three tools allowing you to create generation/simulation signals that vary with time.

Other similar tools:

Stepping on page 73

Manual Stepping on page 78

To open the ramping configuration window, enter the following menu commands: **F1/Setup 1** or **F2/Setup 2** (depending on which window you want to configure the ramping to), **F2/Tools** and **Ramp** from the opened menu. Note that ramping is available for generation/simulation Functions only.

The leftmost picture below shows the configuration window and the rightmost picture the ramping utility in use.

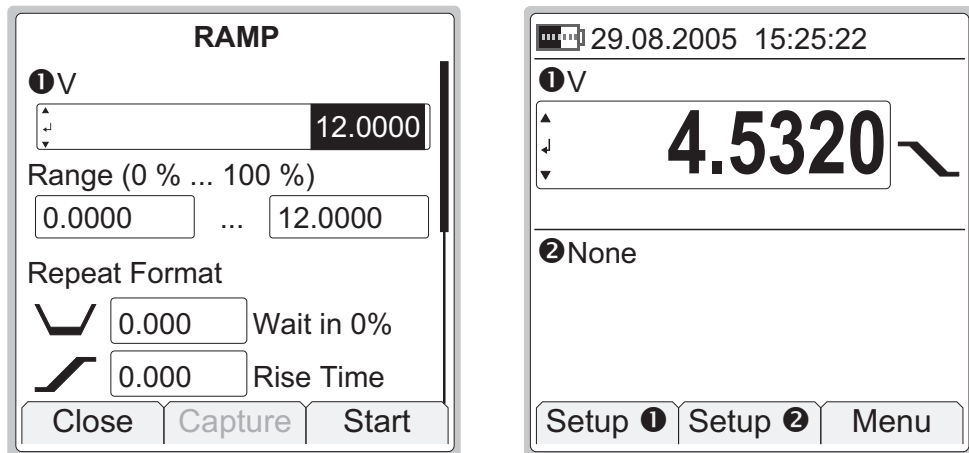

Start ramping by selecting the **F3/Start** Function Key in the configuration window. To stop a ramp that is in progress, open the ramping configuration window and press **F3/Stop** Function Key.

When ramping is ready, or stopped, you may restart it as follows: **F1/Setup 1** or **F2/Setup 2** (depending on which window you want to configure the ramping to), **F1/Start Ramp**. This possibility is available until a new Function is selected for the window where ramping was used or MC4 is shut down.

The following table presents the fields of the configuration window.

FIELD	DESCRIPTION/OPTIONS
Range^(*)	The minimum and maximum value for the ramping range.
Repeat Format Wait in 0% Rise Time Wait in 100% Fall Time	How the ramp should be carried out. Use only full seconds, no decimals.
Repeats	Defines how many times all four phases of the ramp are repeated. Value "zero" equals continuous ramping.

***)Warning!**

Do not configure the range settings so that they exceed the allowed input range of the connected instrument. MC4 determines the limits of the range settings based on the selected quantity and port, not the connected instrument.

Note.

MC4 actually makes the ramp in small steps. The steps are as small as possible, slower ramps use smaller steps.

Manual Stepping

Manual stepping differs from the other two tools allowing you to create varying generation/simulation signals in that the signal does not automatically change. Instead it advances according to the defined steps when you press the up or down arrow keys (▲ ▼), one step at a time.

Other similar tools:

Stepping on page 73

Ramping on page 76

To open the manual stepping configuration window, enter the following menu commands: **F1/Setup 1** or **F2/Setup 2** (depending on which window you want to configure the stepping to), **F2/Tools** and **Manual Stepping** from the opened menu. Note that manual stepping is available for generation/simulation Functions only.

The leftmost picture below shows the configuration window and the rightmost picture the stepping utility in use.

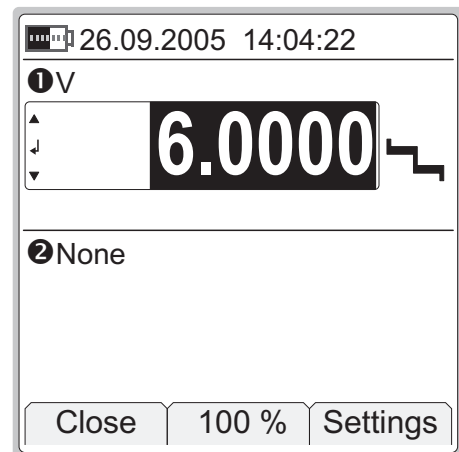
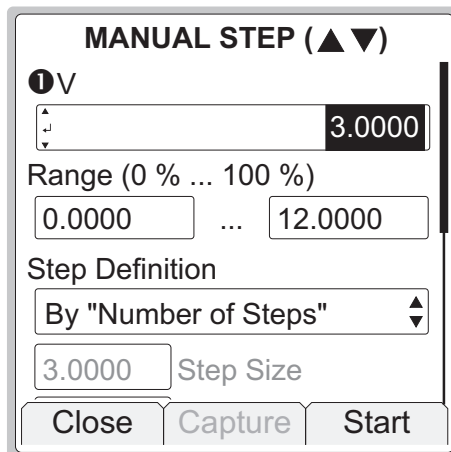

Start manual stepping by selecting the **F3/Start** Function Key in the configuration window. To stop it, press **F1/Close** Function Key (in Basic Mode).

The following table presents the fields of the configuration window.

FIELD	DESCRIPTION/OPTIONS
Range^(*)	The minimum and maximum value for the stepping range.
Step Definition	<p>Defines how the stepping is done Available options (with no custom sets):</p> <p>By 'Step Size' By 'Number of Steps'</p> <p>3: 50 % 5: 25 % 6: 20% 11: 10 %</p> <p>0%>10>25>50>75>90>100 0%>2>4>50>96>98>100 0%>5>40>100 -2%>0>2>4>50>96>98>100>102</p> <p>Create New...</p> <p>The two first options require additional data that is entered in the two following fields.</p> <p>The group of sets starting with a number and colon are sets with fixed step sizes. The first number is the amount of step levels and the percentage value is the step size.</p> <p>The group of sets starting with a number and percentage symbol are sets with varying step sizes (suitable for, e.g. valve tests). Each number is a step level. The last item in the list allows you to make your own custom step definition. See Custom Test Point Sets on page 101.</p>
Step Size	Active only if Step Definition field is set to "By: 'Step Size'". If applicable, set the fixed step size here.
Number of Steps	Active only if Step Definition field is set to "By: 'Number of Steps'". If applicable, set the number of steps here. <i>Continues on next page...</i>

FIELD <i>(cont.)</i>	DESCRIPTION/OPTIONS
<p>Transfer Function</p>	<p>Defines the input/output correlation. Available options:</p> <ul style="list-style-type: none"> Linear √x √x3 √x5 x2 Create New... <p>The last item in the list allows you to make your own custom Transfer Function. See Custom Transfer Functions on page 103.</p>

***)Warning!**

Do not configure the range settings so that they exceed the allowed input range of the connected instrument. MC4 determines the limits of the range settings based on the selected quantity and port, not the connected instrument.

See also:
Spinning and Manual Stepping on page 54.

Display Mode and Special Measurements

The Display Mode and Special Measurements utility is always available, but the available options vary depending on the selected Function.

All Display Mode settings are in: **F1/Setup ①** or **F2/Setup ②** (depending on which window you want to change the display mode for), **F2/Tools**. Select **Display Mode / Specials** from the opened menu.

When a Display Mode or a Special Measurement is active, the measurement window display a warning (⚠) to indicate that the reading is not the actual measured value. Depending on the selected Display Mode or Special Measurement, some additional text is also shown.

All Display Mode and Special Measurement settings revert to Normal display mode if you select another quantity. Additionally, the same menu were a Display Mode or a Special Measurement was invoked also includes a possibility to revert back to **Normal Display Mode**.

Note applying to all display modes and special measurements.

While performing display mode and/or special measurement calculations, MC4 uses numbers that have more decimals than are available on the display. In some cases these extra digits may cause rounding that differs from values that are shown on display. Notable differences between shown and manually calculated values usually mean that MC4's accuracy is not suitable for the given task.

Error %

Error Percentage display compares the measurements of the two windows based on entered measurement range values. The window the Error Percentage display was invoked from is considered the "output" of the instrument and the other window the "input".

The Error Percentage value is shown in the "output" window and the actual "output" signal is by default shown on the additional info row as seen in the rightmost picture.

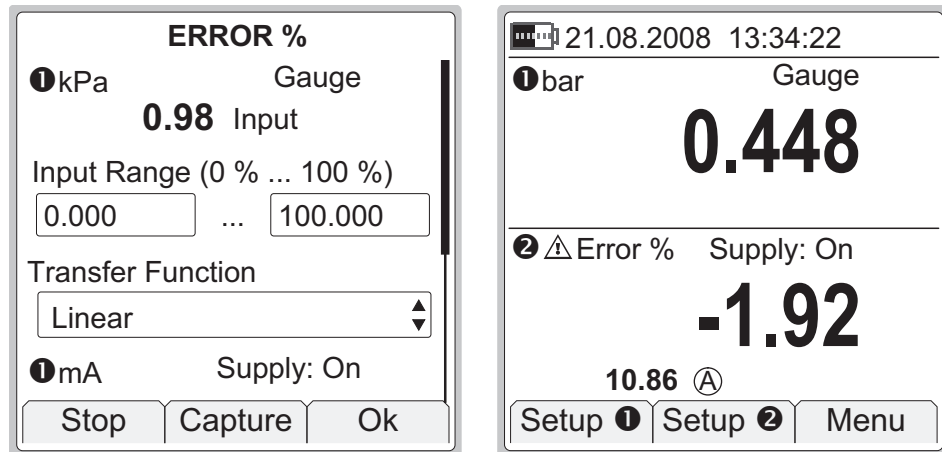

When Error Percentage display is active, the words "**Error %**" is displayed after the warning triangle.

To configure the error percentage display (and also the other types of error displays) you need to enter input and output range values to both windows.

In addition to the range you may also set the **Transfer Function** (Input/Output relationship). Default value is: **Linear**.

The display resolution may also be edited, if needed.

Notes.

If anything else was selected for display on the additional info row, the main measurement of the Error percentage window replaces the previous additional info data.

Also: if you select two other items to be displayed on the additional info row while an error display is active, the second item replaces the windows' main measurement data. **Beware of the problems that may result in not seeing the true measurement value.**

For help on making **Custom Transfer Functions**, see Part C, chapter **Custom Transfer Functions** on page 103.

Error in Input Units

Error In Input Units display compares the measurements of the two windows based on entered measurement range values. The window the Error display was invoked from is considered the "output" of the instrument and the other window the "input".

The Error In Input Units value is shown in the "output" window and the actual "output" signal is shown on the additional info row as seen in the rightmost picture.

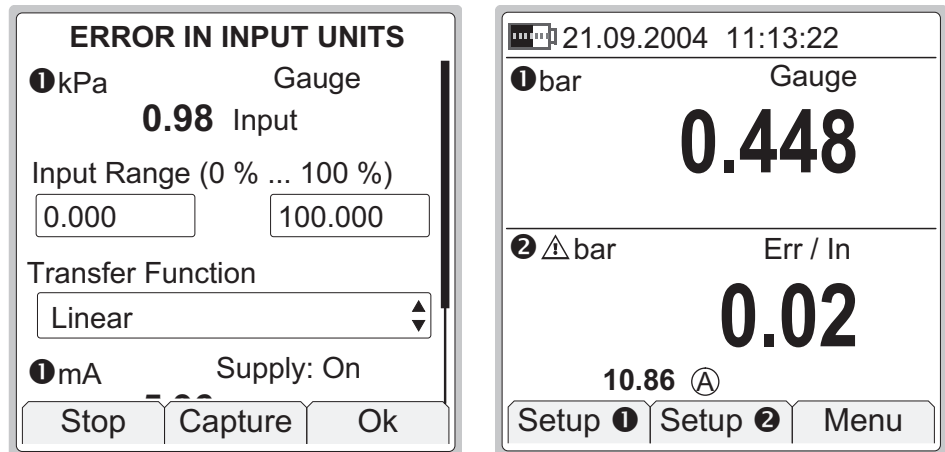

When Error In Input Units display is active, the warning triangle is shown together with the input unit and the text "**Err / In**" is shown above the Error value.

Error displayed in input units is in all other ways similar to error displayed in error percentage. The only difference is in how the calculated error is displayed.

For configuration details, refer to **Error %** on page 82.

Error in Output Units

Error In Output Units display compares the measurements of the two windows based on entered measurement range values. The window the Error display was invoked from is considered the "output" of the instrument and the other window the "input".

The Error In Output Units value is shown in the "output" window and the actual "output" signal is shown on the additional info row as seen in the rightmost picture.

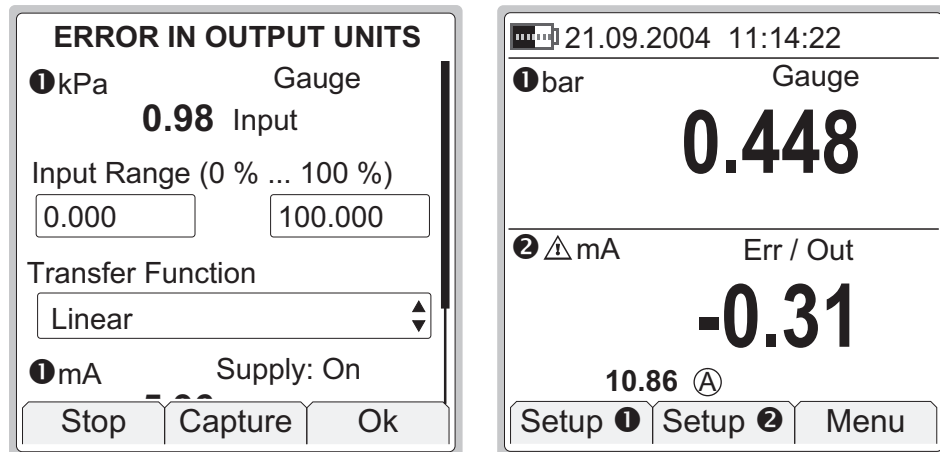

When Error In Output Units display is active, the warning triangle is shown together with the input unit and the text "**Err / Out**" is shown above the Error value.

Error displayed in input units is in all other ways similar to error displayed in error percentage. The only difference is in how the calculated error is displayed.

For configuration details, refer to **Error %** on page 82.

Percentage

Percentage display compares the measured/generated/simulated value against an entered range (0 % and 100 %).

When measuring, the measured value is replaced by the Percentage value. The measurement value in engineering units is shown on the additional info row as seen in the rightmost picture.

When generating/simulating, the Percentage is the editable value and the generated/simulated value in engineering units is shown on the additional info row.

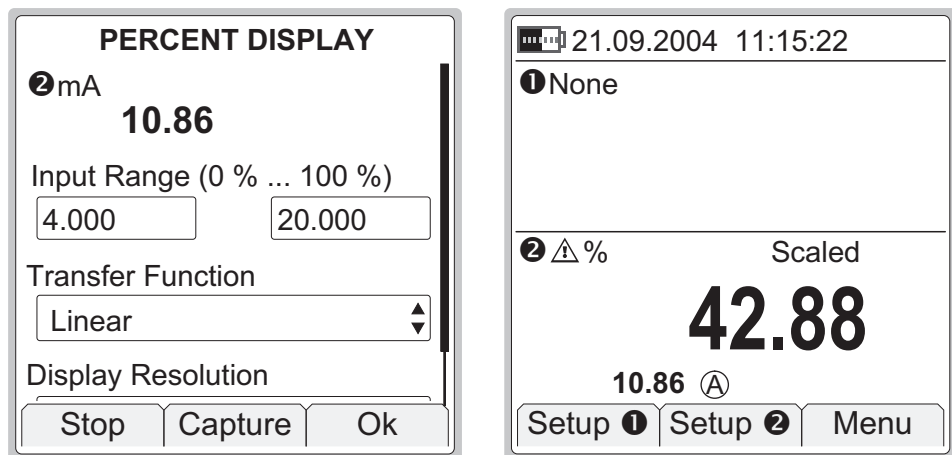

When Percentage display is active, the letter "%" is displayed after the warning triangle and the text "**Scaled**" is shown above the Percentage value.

To configure the percentage display, enter input range values for the selected quantity.

In addition to the range you may also set the **Transfer Function** (Input/Output relationship). The display resolution may also be edited, if needed.

Notes.

If anything else was selected for display on the additional info row, the main measurement of the window with percentage display replaces the previous additional info data.

Also: if you select two other items to be displayed on the additional info row while Percentage display is active, the second item replaces the windows' main measurement data. **Beware of the problems that may result in not seeing the true measurement value.**

For help on making **Custom Transfer Functions**, see Part C, chapter **Custom Transfer Functions** on page 103.

Scaling

In Scaling a measured/generated/simulated value may be converted to whatever "quantity" is needed, provided the conversion information is known.

When measuring, the measured value is replaced by the scaled value. The actual measurement value in engineering units is shown on the additional info row as seen in the rightmost picture.

When generating/simulating, the scaled value is the editable one and the generated/simulated value in engineering units is shown on the additional info row.

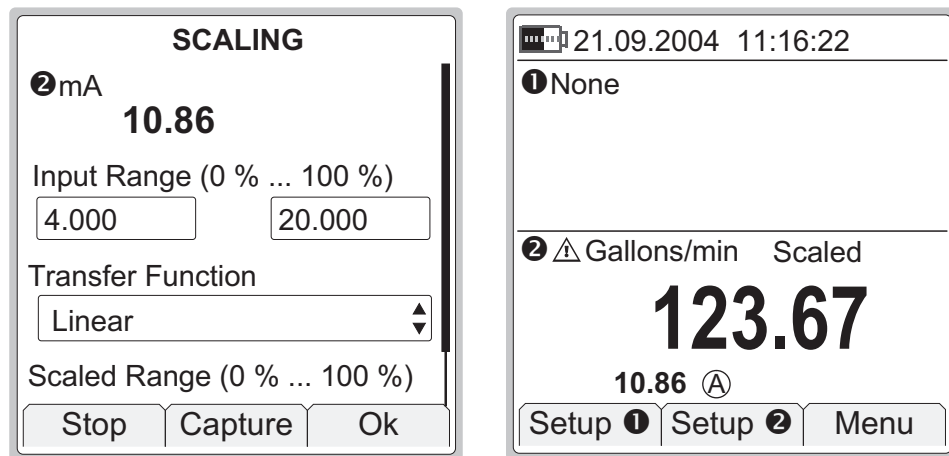

When Scaling display is active, the entered unit (or the text "**scaled unit**" if the unit was not entered) is displayed after the warning triangle and the text "**Scaled**" is shown above the Scaled value.

To configure Scaling, enter **Input Range** values for the selected quantity, set the **Transfer Function**, enter the **Scaled Range** and the **Unit** of the scaled range. The display resolution may also be edited, if needed.

Notes.

If anything else was selected for display on the additional info row, the main measurement of the window replaces the previous additional info data.

Also: if you select two other items to be displayed on the additional info row while Scaling display is active, the second item replaces the windows' main measurement data. **Beware of the problems that may result in not seeing the true measurement value.**

For help on making **Custom Transfer Functions**, see Part C, chapter **Custom Transfer Functions** on page 103.

Deviation

Deviation measurement compares a measured value against an entered reference value. The reference value is subtracted from the reading of the measured value. The difference replaces the measurement value. Both the reference value (indicated with a triangle) as well as the actual measurement value (indicated with a circled A) are shown on the additional info row as seen in the picture.

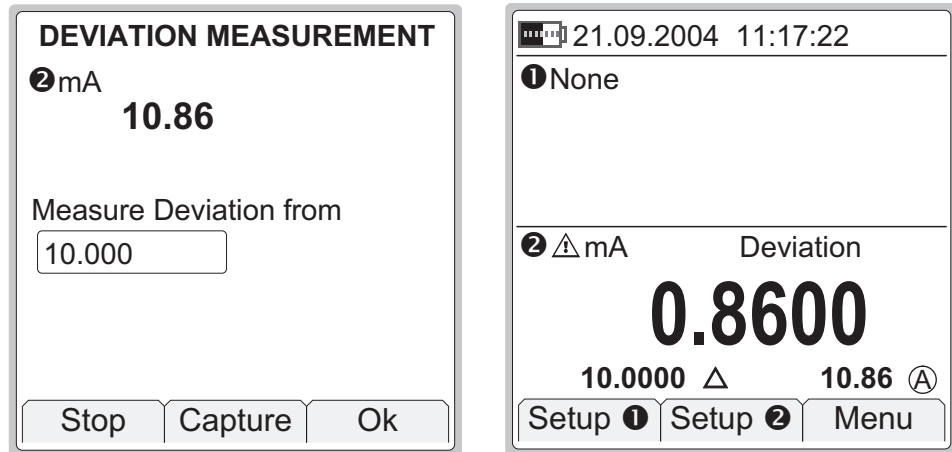

When Deviation measurement is active, text "**Deviation**" is shown above the Deviation value.

Hint.

Use the **F2/Capture** Function Key to add a measured "tare" as the reference value.

Notes.

If anything else was selected for display on the additional info row, the main measurement of the window replaces the previous additional info data.

Also: if you select two other items to be displayed on the additional info row while Deviation measurement is active, the second item replaces the windows' main measurement data. **Beware of the problems that may result in not seeing the true measurement value.**

Warning.

Keep in mind that when the displayed deviation reading is small compared to the actual reading, a significant part of the deviation value may be measurement error. See the specifications for measurement errors at the actual measurement level.

Redundant

In Redundant measurement two similar measurements (e.g. pressure measurement using both the internal and an external pressure module) are compared with each other. If the readings differ more than the entered limit value, MC4 gives an audible alarm.

The selected main measurement is shown normally. The secondary measurement value (indicated with a circled B) as well as the alarm limit (indicated with a triangle) are shown on the additional info row as seen in the rightmost picture.

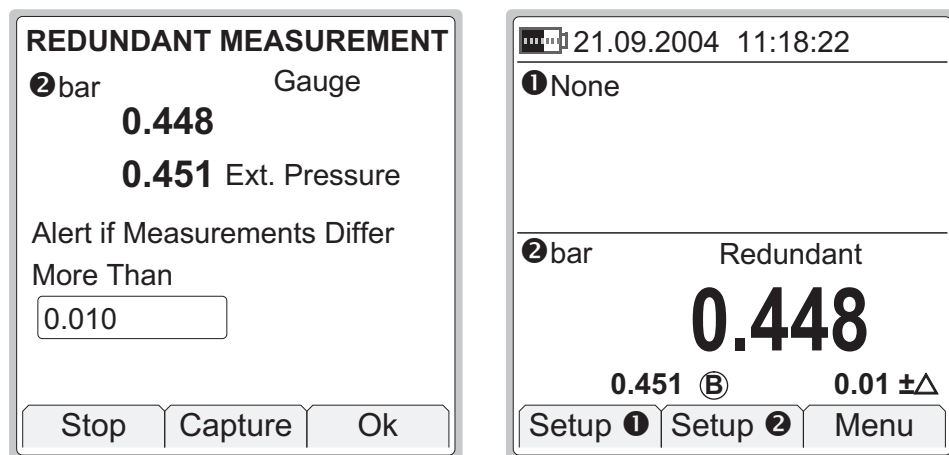

When Redundant measurement is active, text "**Redundant**" is shown above the main measurement value.

Notes.

If anything else was selected for display on the additional info row, the alarm limit and the secondary measurement replaces the previous additional info data.

Also: if you select other items to be displayed on the additional info row while Redundant measurement is active, the items replace the redundant measurement related data. **Beware of the problems that may result in not seeing the true measurement value.**

Redundant measurement can be activated only if two similar measurements are available, and neither of them is used for any other measurement.

Warnings.

When setting the allowed difference, take the accuracies of the measurements into account.

If the measuring spans of the selected ports are different, make sure you do not exceed the measurement range of either port.

Difference

In Difference measurement, two similar measurements (e.g. pressure measurement using both the internal and an external pressure module) are subtracted.

The Difference replaces the main measurement value. The main measurement (minuend, indicated with a circled A) as well as the secondary measurement value (subtrahend, indicated with a circled B) are shown on the additional info row as seen in the picture.

Difference measurement is active, text "**Difference**" is shown above the Difference value.

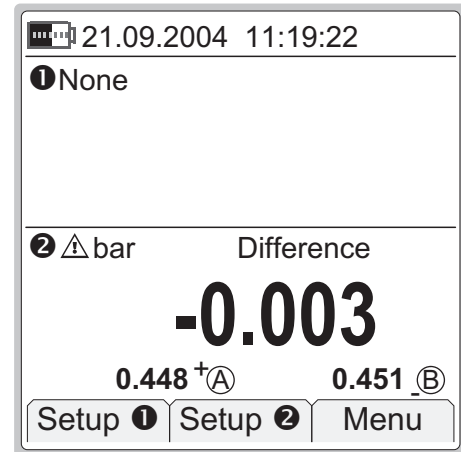

Notes.

If anything else was selected for display on the additional info row, the main measurement of the window replaces the previous additional info data.

Also: if you select other items to be displayed on the additional info row while Difference display is active, the items replace the Difference related data. **Beware of the problems that may result in not seeing the true measurement values.**

Difference measurement can be activated only if two similar measurements are available, and neither of them is used for any other measurement.

Warnings.

Keep in mind that when the displayed Difference reading is small compared to the actual reading, a significant part of the Difference value may be measurement error. See the specifications for measurement errors at the actual measurement level.

If the measuring spans of the selected ports are different, make sure you do not exceed the measurement range of either port.

Showing Data on the Additional Info Row

As presented in section A's User Interface chapter, both Basic Mode windows have an Additional Info row for showing additional data. Each window may have two values shown on their respective Additional Info rows. The only exception is the bar graph option. It reserves the whole Additional Info row alone.

All Additional Info Row settings are in: **F1/Setup ①** or **F2/Setup ②** (depending on which window you want to change the display mode for), **F2/Tools**. Select **Show Additional Info** from the opened menu.

The data available to be shown on the Additional Info row can be divided into following groups:

- **Data that is Always Available.**
Can be selected to be shown at any time.
- **Display Mode and Special Measurement Related Data.**
Data that is available to be shown depending on Display Mode and Special Measurement settings.
- **Function Dependent Data.**
Data that is available for certain Functions, e.g. barometric pressure when it is needed.

The following chapters present the data available to be shown on the Additional Info row. Any limitations as to when the data is available are mentioned where applicable. Below each heading is the icon or unit displayed on the Additional Info row when that particular Additional info is shown.

Maximum value

↕ Displays the found maximum value after a measurement was started or it was reset.

Minimum value

↕ Displays the found minimum value after a measurement was started or it was reset.

Rate of Change Value (unit 1/min)

↗ Displays the calculated rate of change value (units/min) found after a measurement was started or the calculation was reset.

Maximum - Minimum

± Calculates the difference between the maximum and minimum measurement value found after a measurement was started or it was reset.

Cumulative Average

\bar{x} Calculates the cumulative average of measurements after a measurement was started or it was reset.

Cumulative average means that, after the calculation is started, every new measurement is included in the average calculation. Thus the amount of measurements included in the cumulative average increases all the time and the average value's change rate typically gets smaller with time.

Internal Temperature

°C,
°F or
K When an internal or an external pressure module is used in a window, the internal temperature of the pressure module can be selected to be shown.

Normal Reading

Ⓐ Normal Reading refers to the window's **main measurement**. It is available when the following Special Measurements reserve window's main value: All **Error Display Modes** as well as **Percentage, Scaling** and **Deviation** measurement.

Deviation Reference

△ Available when deviation measurement is active. This is the entered reference value MC4 uses to calculate the measurement's deviation from.

Redundant Measurement (Secondary Measurement)

Ⓑ The secondary measurement used during redundant measurement.

Redundant Reference

+△ The alert limit that is entered when redundant measurement was started. Available only when redundant measurement is active.

Difference A

+Ⓐ Displays the main measurement during a difference measurement.

Difference B

B Displays the secondary measurement during a difference measurement.

Barometric Pressure

P_B Displays the barometric pressure value that is used for measurement's pressure type conversion. This value comes usually from built-in barometer, but some high-pressure modules may allow using manually entered barometer value.

Feedback Measurement

V, mV, μV, mA, μA, °C, °F or K Available for the following generation/simulation Functions:
(same unit as main value)

- **Voltage Generation**
- **Low-Voltage Generation**
- **T/C Sensor Simulation**
- **Current Source or Sink**

When MC4 generates voltages or current, it uses its own measurement Functions to control the generated value. This feedback measurement may be displayed on the Additional Info row.

Thermovoltage, RJ = 0°C

mV₀ Displays the thermovoltage for reference junction temperature 0°C. Suitable for referring to thermovoltage table values. Available for **T/C Sensor Measurement** and **T/C Sensor Simulation** Functions with temperature unit selected.

Thermovoltage

mV Displays the actual measured thermovoltage for reference junction temperature. Available for **T/C Sensor Measurement** and **T/C Sensor Simulation** Functions.

RJ Temperature

°C, °F or K Displays the temperature of the reference junction in use. Available for **T/C Sensor Measurement** and **T/C Sensor Simulation** Functions.

Sensor Resistance

Ω Displays the real resistance MC4 is measuring or simulating for an **RTD sensor** Function.

Pulses Done

Displays the pulses currently done during **Pulse Generation**.

Pulses Left

Displays the pulses currently left to be done during **Pulse Generation**.

Bar Graph

A Bar Graph is always available in the list of Additional Info row data, but the type of Bar Graph depends on the Display Mode and Special Measurement settings. The bar graph is always related to the main value (big numbers) and its units, so configure the Bar Graph's range accordingly.



If any of the Error Display Modes is active, the Bar Graph displays a graphical presentation of the error value. The middle of the graph represent zero error and the symmetrical "width" of the graph is user configurable

Resetting and Clearing Additional Info Row / Calculations

Active minimum, maximum, rate of change, maximum – minimum and cumulative average calculations may be reset using the additional option found in the window's Tools menu: **Reset Min / Max / Rate**.

Changing the Function for a window sets all Additional Info data to default values (usually nothing).

Activating a Display Mode or a Special Measurement often replaces them with data related to the activated Display Mode or Special Measurement. Any previously activated minimum, maximum or rate of change calculations are still working, but are no longer shown (until selected to be shown again).

(Empty)

Advanced Operation and Configurations

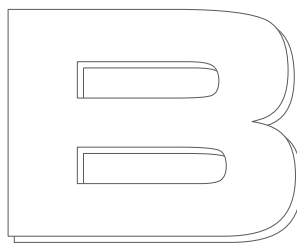
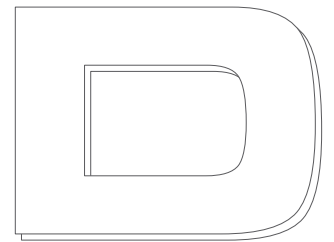

Things discussed in Part C:

- Advanced tools found in the Utilities Menu.
- Help on how to create customized test point sets and transfer functions.
- Related information: Useful during pressure measurement, thermocouple measurement/simulation and resistance/RTD measurement/simulation.

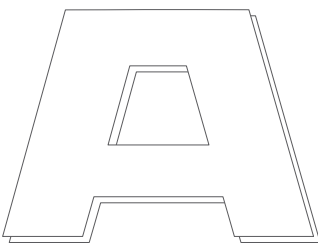

Utilities Menu

This chapter and its subchapters present items available in the utilities menu that opens from Basic Mode by pressing **F3/Menu**.

About This Calibrator

Opens a window presenting basic information of MC4.

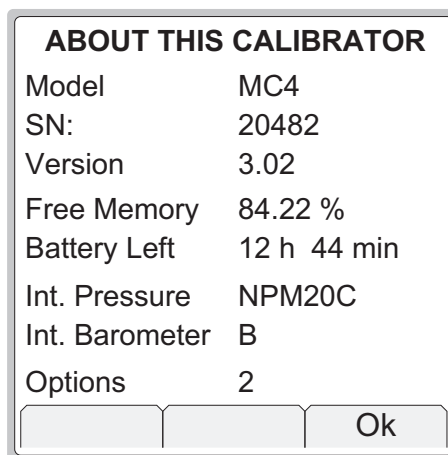

Battery Left is an estimate of remaining usage time.

Pressure modules, if any, are listed below the usage time estimate.

Instrument Calibration

Instrument calibration opens new windows for entering instruments, selecting them for calibration and calibrating the selected instrument.

Part D of this manual is dedicated to this functionality.

User Setups for ❶ & ❷

MC4 supports saving user settings for window ❶ and window ❷. The available free memory defines how many user settings may be saved.

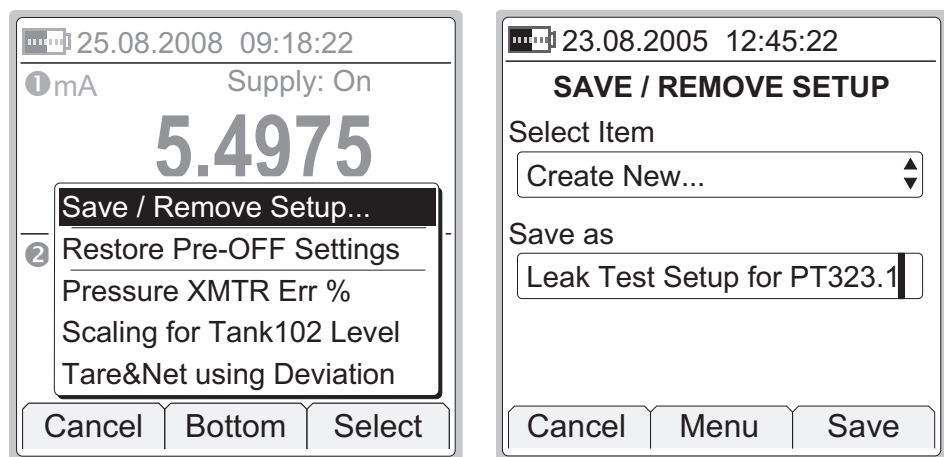

In the leftmost picture above, three User Setups are already saved. Selecting Save / Remove Setup option opens the **SAVE / REMOVE SETUP** window allowing you to save the current settings for window ❶ and window ❷ (see rightmost picture).

About the second item on the list shown in the leftmost picture above: **Restore Pre-OFF Settings**:

MC4's startup is made as straight forward as possible. It does not automatically restore its more advanced functions (display mode, special measurements etc.) used when MC4 was shut off. By selecting the **Restore Pre-OFF Settings** option, it is possible to restore MC4's advanced functions used before it was last shut off.

Date/Time

Allows you to select the displayed date and time formats according to your needs. This window is also used to set date and time. Use the **day**, **month**, **year** and **hour (24)**, **min**, **sec** fields to set the date/time.

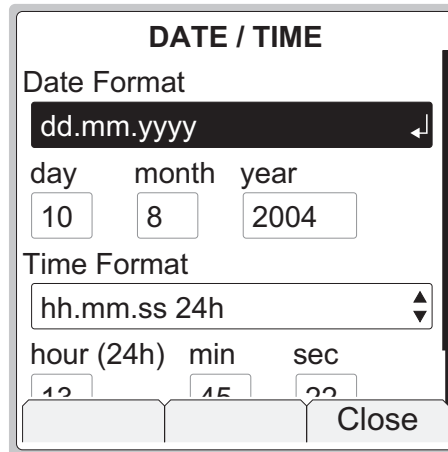

The screenshot shows a window titled "DATE / TIME". It contains two main sections: "Date Format" and "Time Format".

Date Format: A dropdown menu is set to "dd.mm.yyyy". Below it are three input fields labeled "day", "month", and "year" with values "10", "8", and "2004" respectively.

Time Format: A dropdown menu is set to "hh.mm.ss 24h". Below it are three input fields labeled "hour (24h)", "min", and "sec" with values "12", "15", and "22" respectively.

A "Close" button is located at the bottom right of the window.

Notes.

The time must always be given in the **24 hour** format no matter what the configured time format is.

Date and time will be immediately updated when you change the value of any of the time related fields.

General Settings

This window allows you to edit the following settings:

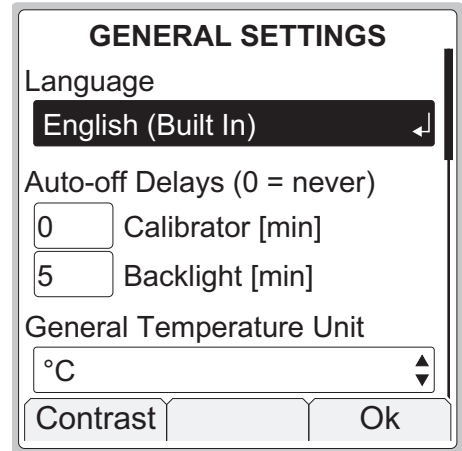

FIELD	NOTES
Language	Contains a list of User Interface languages.
Auto-off Delays: Calibrator [min] Back light [min]	Wait time before auto power off is executed and before the display light is automatically switched off. See also notes after this table. Value 0 (zero) means the Auto-off delay is disabled.
General Temperature Unit	Select either °C (Centigrade) or °F (Fahrenheit) as the temperature unit.
Temperature Scale	Contains a list of standard temperature scales.
Key Click Volume, Alarm Volume, Attention Volume, Outside Span Volume and, Error Volume	Available options (apply to all volume settings): Off, Low, Medium and High.
Net Frequency	Options: 50 Hz and 60 Hz. Note that wrong net frequency setting affects the accuracy of MC4.
Owner	A text field for entering owner's name etc. This data is shown in the Welcome Screen.

Notes.

All changes in general settings become valid immediately except when changing the language. To activate the new language, shut off and restart MC4.

Disable auto-off delay during long-time tasks (e.g. leak/stability test). Otherwise the auto-off functionality interrupts the task.

When calibrator's **Auto-off delay** is in use (value other than zero), a warning dialog pops up 30 seconds before the auto power off executes. In the dialog the Function Keys have the following options:

- **F1/Cancel**
Cancels the auto power off feature *for the moment*, but it stays active even during this session.
- **F2/Stop**
Disables the auto power off feature *for this session*. It will reactivate when the calibrator is switched on the next time.
- **F3/Ok**
Immediately shuts down the calibrator.

Calibrator Adjustment

Opens a window to start the recalibration and adjustment of MC4.

See Appendix 2 for instructions on how to recalibrate MC4.

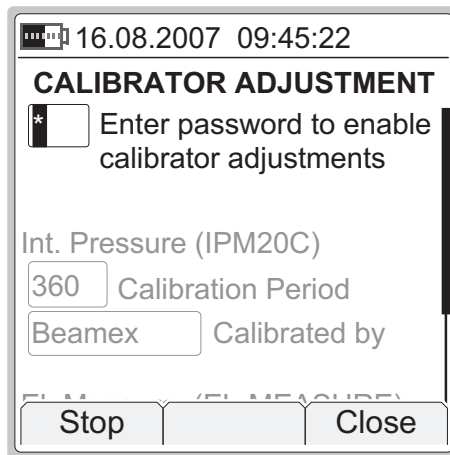

Custom Test Point Sets

MC4 has a comprehensive set of pre-entered test point sets (steps). If however they are not suited for your needs, you can create your own test points as presented here.

In **Basic Mode**, custom test point definition can be started from the following utilities found in the **Tools** menu for generation/simulation Functions:

- Stepping presented on **page 73** and
- Manual Stepping presented on **page 78**.

One of the utilities' configuration fields is **Step Definition** combo. The last option in the combo is **Create New**. It opens the custom test point tool. If a custom set already exists, selecting it in the **Step Definition** combo also opens the custom test point tool.

In **Calibration Mode**, custom test point definition can be started while editing instrument data. See:

- Procedure Data Page presented on **page 165**.

In this case, the custom test point tool opens from **Calibration Points** combo.

Give a name to the Custom test point set. The **Scaled Range** initially has the same range as defined for the Stepping or Manual Stepping from where the custom test step definition was invoked. You may edit the **Scaled Range** according to your own needs during step definition, e.g. scale the steps to percentage values.

Enter the point values. Press down arrow (▼) to add a point below the last point.

EDIT TESTPOINT SET

Set Name

Scaled Range (0 % ... 100 %)
 ...

1.	<input type="text" value="4.0000"/>	0 %
2.	<input type="text" value="6.0000"/>	13 %
3.	<input style="background-color: #cccccc;" type="text" value="7.5000"/>	22 %

The **F2/Menu** Function Key opens a menu for editing the test point rows or the whole set. Options:

- **Insert Row**
- **Delete Row**
- **Delete All Rows**
- **Copy Set**
- **Delete Set**

The **Insert Row** option adds a point **above** the current point.

The **F3/Ok** Function Key saves the custom test point set and adds it to the **Define Steps** combo list. It is located after all pre-entered test point sets, before the **Create New** option.

To separate custom point sets from pre entered ones, custom point sets are prefixed "User:" and the row ends with a chevron pointing right ">". This indicates that the point set may be edited.

Hints!

The point values need not be in ascending order or even inside the range limits.

To force MC4 to stay in one point for a longer time, enter the same point value to several successive points.

Notes.

The step values are saved as floating point number percentage values so the steps may be used for any Function and range. The percentage values are proportioned to the current **Stepping / Manual Stepping** range.

The percentage values shown to the right of the test points are whole number near values of the entered values. They are for information only.

The available free memory defines how many custom test points may be saved. If there is not enough memory left to save a custom test point set, MC4 displays an error message suggesting that you first free some memory and then retry adding a custom test point set.

Custom Transfer Functions

MC4 has a pre-entered set of standard transfer functions. If however they do not suit your needs, you can create your own transfer functions as presented here.

In **Basic Mode**, custom transfer function definition can be started from the following **Display Modes** (found in the **Tools** menu of **measurement Functions**):

- Error % presented on **page 82**,
- Error in Input Units presented on **page 83** and
- Error in Output Units presented on **page 84**.

And from the following **Display Modes** (**always** available in the **Tools** menu):

- Percentage presented on **page 85** and
- Scaling presented on **page 86**.

And also from the **Tools** menu of the following **generation/simulation** Function utilities:

- Stepping presented on **page 73** and
- Manual Stepping presented on **page 78**.

One of the combos in all of the above mentioned utilities is called **Transfer Function**. The last option in the combo is **Create New**. It opens the custom transfer function tool. If a custom transfer function already exists, selecting it in the **Transfer Function** combo also opens the custom transfer function tool.

In **Calibration Mode**, custom transfer function definition can be started while editing instrument data. See:

- Function Data Page presented on **page 163**.

Just as in Basic Mode, look for a **Transfer Function** combo.

Give a name to the custom transfer function.

The **Input Range** and **Output Range** fields are scaled ranges for the custom transfer function. Default values are for percentage scaling.

Enter Input/Output pair values in ascending order. Press down arrow (▼) to add more Input/Output pairs below the last Input/Output pair.

The **F2/Menu** Function Key opens a menu for editing the Input/Output pairs or the whole set. Options:

- **Insert Row**
- **Delete Row**
- **Delete All Rows**
- **Copy Set**
- **Delete Set**

The **Insert Row** option adds an Input/Output pair **above** the current Input/Output pair. The new row has default values based on the Input/Output pairs above and below it (calculated using linear approximation).

The **F3/Ok** Function Key saves the custom transfer function and adds it to the **Transfer Function** combo list. An inverted copy of the custom transfer function is also added to the **Transfer Function** combo list. The inverted transfer function has a "x⁻¹" symbol before its name. The custom transfer function and its inverted copy are located after all pre-entered transfer functions but before the **Create New** option.

To separate custom transfer functions from pre entered ones, custom transfer functions are prefixed "User:" and the row ends with a chevron pointing right "⟩". This indicates that the point set may be edited.

Hint!

The maximum Input/Output pair values may be outside the ranges' maximum values.

Notes.

The Input/Output pairs are saved as floating point number percentage values so the transfer function may be used for any function and range. The percentage values are proportioned to the current range.

The available free memory defines how many custom transfer functions and Input/Output pairs may be saved. If there is not enough memory left to save a custom transfer function, MC4 displays an error message suggesting that you first free some memory and then retry adding a custom transfer function.

MC4 approximates the values between entered input/output pairs by calculating a curve between a pair of points that connects smoothly to the adjoining curve. The entered Input/Output pairs need to be points of a strictly increasing function.

Custom PRT Sensors

Although MC4 has a wealth of pre entered standard **Platinum Resistance Temperature (PRT)** type RTD sensors, some additional sensors definitions may be needed. This especially when a PRT sensor is used as a reference sensor. These sensors often have custom coefficients in their Callendar - van Dusen equation.

More of Callendar - van Dusen equation in chapter **Callendar - van Dusen Equation** on page 107.

Creating Custom PRT Sensors

You may create up to 100 custom PRT sensors.

To create a custom PRT sensor, configure one of the Basic State's windows (select **F1/Setup ①** or **F2/Setup ②**) for PRT sensor measurement or PRT sensor simulation. While configuring, open the **Sensor** combo and select the **Create New** option. A window for defining the coefficients for the Callendar - van Dusen equation opens. Give the sensor a name and enter the coefficients (for reference sensors the coefficients can be found in their calibration certificate). Then save the sensor definition.

Saved custom PRT sensors can be seen in the PRT sensor list. To separate them from pre entered sensors, they are prefixed "User:" and the row with a custom PRT sensor ends with a chevron pointing right (\rangle). This indicates that the sensor may be edited.

Notes.

Make sure you do not run any tasks found in the **Tools** menu (e.g Scaling) while editing a custom PRT sensor. All **Tools** menu tasks utilize the custom PRT sensor as it was when starting the task.

See also Part B, chapter **Scaling**.

Callendar - van Dusen Equation

The relationship between a Platinum Resistance Temperature (PRT) sensor's resistance and temperature can be generated from the Callendar - van Dusen equation:

Below 0 °C:

$$R_t = R_0 \cdot \left[1 + A \cdot t + B \cdot t^2 + C \cdot (t - 100^\circ) \cdot t^3 \right]$$

Above 0 °C:

$$R_t = R_0 \cdot \left[1 + A \cdot t + B \cdot t^2 \right]$$

Where:

R_t is the resistance in Ohms at temperature **t**

R₀ is the resistance in Ohms at 0 °C

t is the temperature in °C

A, **B** and **C** are customizable factors.

For standard sensors the factors **A**, **B** and **C** are already defined, but real life (reference) sensors may require slightly different factors.

Note.

Callendar - van Dusen equation applies to Platinum Resistance Temperature (PRT) type RTD sensors only. Other types of RTD sensors cannot be customized using this equation.

Custom Pressure Units

MC4 has a comprehensive set of pre-entered pressure units. If however they are not suited for your needs, you can create up to four custom pressure units.

To define custom pressure units, configure one of the Basic State's windows (select **F1/Setup ①** or **F2/Setup ②**) for pressure measurement. While configuring, open the Unit combo and select one of the "User" units. They can be found at the bottom of the list of pressure units (as long as they are not in use and not selected to the "favorites" list).

When selecting a user configurable unit, a window opens for configuring the unit.

Saved custom pressure units can be seen in the pressure unit list. To separate them from pre entered units, they are prefixed "User:" and the row with a custom pressure unit ends with a chevron pointing right "⟩". This indicates that the unit may be edited.

USER UNIT SETTINGS

User Unit Name

Factor

Reference Unit

Cancel Ok

Notes.

Make sure you do not run any tasks found in the **Tools** menu (e.g Scaling) while editing a user defined unit. All **Tools** menu tasks utilize the user defined unit as it was when starting the task.

See also Part B, chapter **Scaling**.

Related Information

Most of the measurements, generations and simulations presented in this manual are straight forward: Just make the required window settings and connect the instrument under test to the active terminals and that's it!

Some cases require additional settings and things to check before you can be certain that the measurement, generation or simulation works as expected. A typical example of this is temperature measurement using a thermocouple. It is not enough to select the correct Function in MC4. The Sensor type and the Reference Junction Mode has to be set accordingly, too. Wrong settings give erroneous results.

Whenever this additional information may be of use in a measurement, generation or simulation, text describing the Function refers to one of the following chapters. An experienced may skip this supplemental text, but for a beginner we highly recommend it.

The subjects described here are:

- **Things to Consider when Measuring Pressure** on page 110,
- **Pressure Type** on page 110,
- **Pressure Modules and their Naming Conventions** on page 111,
- **Square Rooting** on page 112,
- **Thermocouple Measurement/Simulation, Connections and Troubleshooting** on page 113,
- **Resistance and RTD Measurement, Connections** on page 118,
- **Current Measurement Parallel to a Test Diode, Connections** on page 120 and
- **Parallel Functions in MC4** on page 121.

Things to Consider when Measuring Pressure

General

MC4 can measure pressure with its internal pressure module or with external pressure modules. If a barometric module is present, the measurement results of other modules can be shown either as absolute pressure or as gauge pressure.

Pressure Type

Every pressure measurement is in fact a pressure difference measurement: a given pressure value is compared against a reference pressure. In certain cases the reference pressure has a special meaning (like the atmospheric pressure) and the pressure measurements with reference to against these points are given a special name:

- **Absolute pressure measurement** uses vacuum as the reference pressure.
- **Barometric pressure** (or **atmospheric pressure**) is the absolute pressure of the surrounding atmosphere. It is specially titled because of its importance.
- **Gauge pressure measurement** uses the atmospheric pressure as the reference. Gauge pressure may be zero, negative or positive. Most of MC4's pressure modules actually measure gauge pressure although they may be used for measuring other pressure types too.
- **Differential pressure measurement** requires a special differential pressure module that has an input available for both the reference pressure and the given pressure.

To be able to measure absolute pressure with MC4's gauge pressure modules, you need a barometric pressure module. Certain high pressure modules may approximate absolute pressure measurement by adding an entered barometric pressure to the measured gauge pressure.

MC4 may use two standard pressure modules to measure (pseudo) differential pressure: One module measures the reference pressure and another the given pressure. The pressure difference is calculated by subtracting the reference pressure from the given pressure. More of this in Part B, chapter **Display Mode and Special Measurements**.

Always ensure that the pressure type setting of your pressure measurement is what you intended it to be. The pressure type setting is crucial for getting meaningful pressure measurement results.

Pressure Modules and their Naming Conventions

MC4's software refer to pressure modules as follows:

NPM200mC

which means that there is an **internal pressure module** installed with a **-200 to +200 mbar** (-3 to +3 psi) pressure range.

The names of MC4's internal pressure modules start with the letters **NPM**. The names also include numbers and possible additional letters as follows:

- The number defines the max. nominal pressure in the SI pressure unit **bar**.
- If the number is followed by a small "m", the given max. nominal pressure is given in **mbar**.
- The additional letter **C** means the pressure module is a compound module with an ability to also measure negative gauge pressures.

Examples: Name	Measurement range	in psi
NPM200mC	±200 mbar	± 3
NPM20C	-1 ... 20 bar	-14.5 ... 300
NPM160	0 ... 160 bar	0 ... 2400

Notes.

Compound modules with a max. nominal pressure above 1 bar (e.g. IPM20C) are able to measure negative pressures down to -1 bar. Compound modules with a max. nominal pressure below 1 bar (e.g. IPM200mC) are only able to measure as deep negative pressures as positive pressures.

External pressure modules have a naming convention that is similar to internal ones.

Square Rooting

Pressure transmitters or converters used for flow measurement often have square rooting character. Here are a couple of examples on how you can configure MC4 to take into account the instrument's square rooting character:

1. Set the **Display Mode** of window that measures the instrument's output signal to **Error Percentage** and make sure the **Transfer Function** field is set to Square Rooting (\sqrt{x}).
2. Use **Scaling** to convert the instrument's output signal to a suitable format and again, make sure the **Transfer Function** field is set to Square Rooting (\sqrt{x}).

Display Modes as well as scaling is discussed in chapter **Tools Menu** in part B of this User Guide.

Thermocouple Measurement/Simulation, Connections and Troubleshooting

To accurately measure the thermovoltage caused by the temperature to be measured, the second thermovoltage caused by the Reference Junction needs to be compensated. This is done using one of the Reference Junction compensation methods described in the subsequent chapters.

The Reference Junction compensation method has to be chosen both when measuring and simulating thermocouples.

Internal Reference Junction

MC4's Internal Reference Junction makes thermocouple measurement/simulation easy. No external connections are required, just connect the thermocouple or a thermovoltage receiver directly to MC4's "T/C" terminals. To select this compensation method, set the window's Function to field "**T/C Sensor Measurement**" or "**T/C Sensor Simulation**", make sure the **Unit** is a temperature unit and set the **RJ Mode** field to "**Internal**".

Connection when measuring/simulating thermocouples using Internal Reference Junction Mode:

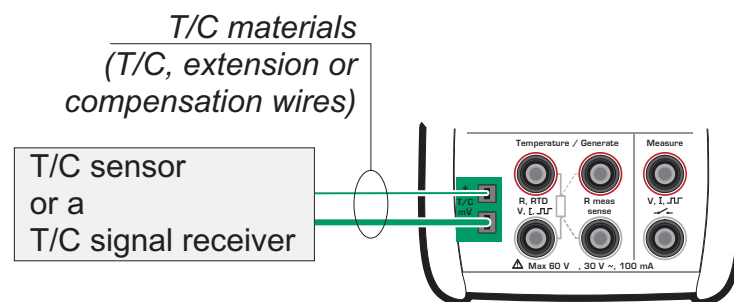

Refer to the Technical Data in Appendix 1 for specifications concerning the Internal Reference Junction.

See also...

External Reference Junction on page 114

External Reference Junction

When using an external Reference Junction, MC4 measures or simulates the thermovoltage using the "T/C" terminals. The following external Reference Junction compensation methods are available:

External RTD:

To be used when:

- The Reference Junction temperature is measured using an RTD sensor connected to MC4's RTD terminals.

Connection when measuring/simulating thermocouples using Reference Junction compensation method "External RTD":

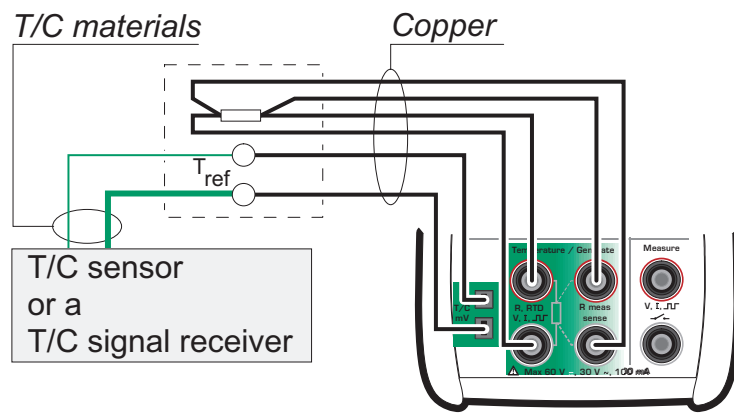

Warning!

If you connect an RTD sensor to the RTD connectors, there is no galvanic isolation between the thermocouple and the RTD sensor.

None (0 °C):

To be used when:

- The Reference Junction temperature is **fixed** to 0°C (using, e.g. ice) and MC4 is not used for measuring the Reference Junction temperature.
- The Reference Junction temperature is **controlled** with 0°C set point.
- A compensation box is used and the Reference Junction temperature setting is 0°C.
- There is no Reference Junction compensation in the measuring/simulation circuit but 0°C is a good enough approximation.

Manually Entered:

Usable when:

- The Reference Junction temperature is **fixed** to a temperature that differs from 0°C.
- The Reference Junction temperature is **controlled** and the controller's set point is not 0°C. Note: this method is of use only if the accuracy of the controller is better than MC4's own Reference Junction.
- A compensation box is used and the Reference Junction temperature setting is other than 0°C.
- There is no Reference Junction compensation in the measuring/simulation circuit, but you want to manually enter another Reference Junction temperature than 0°C.

Connection when measuring/simulating thermovoltages using a temperature controller and either of the following Reference Junction compensation methods:

"Manually Entered" or "None (0 °C)":

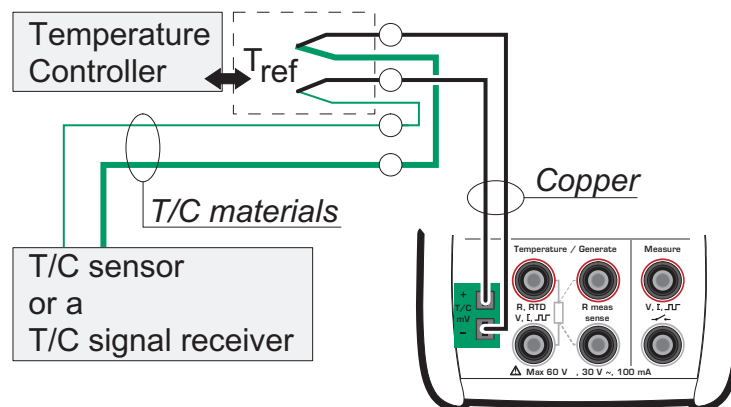

Connection when measuring/simulating thermovoltages using a fixed temperature and either of the following Reference Junction compensation methods:

"Manually Entered" or "None (0 °C)":

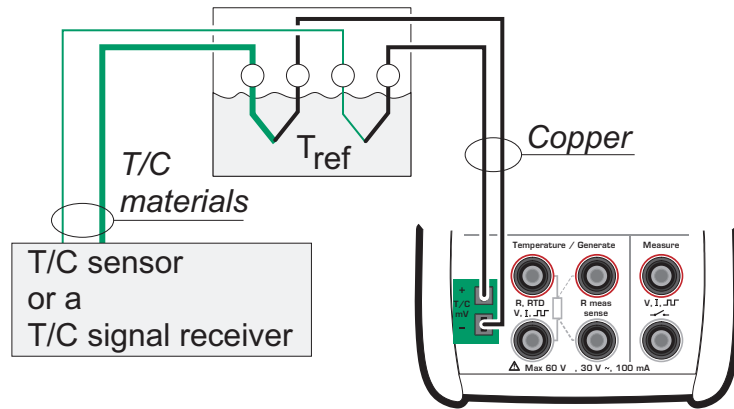

Connection when measuring/simulating thermovoltages using a compensation box and either of the following Reference Junction compensation methods:

"Manually Entered" or "None (0 °C)":

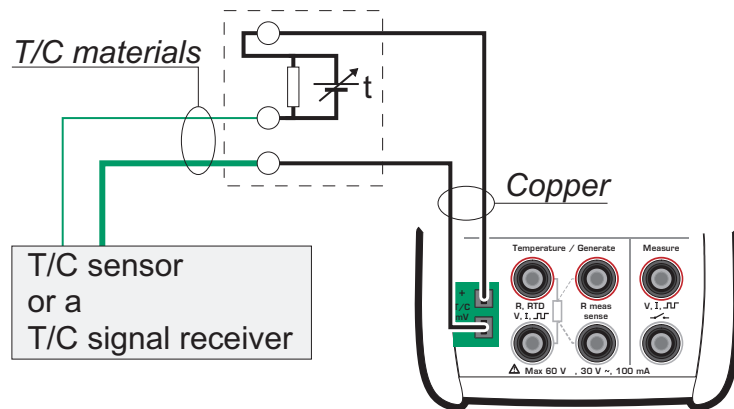

See also...

Internal Reference Junction on page 113

Error situations

The easiest way to avoid errors in thermocouple measurement and simulation is to check carefully the used wiring and the Reference Junction mode. The following table describes the typical error situations and possible causes/corrections when working with thermocouples:

PROBLEM	CAUSE
MC4 (or the instrument under test when simulating thermovoltages) measures the temperature/millivolt signal, but the displayed temperature reading is all wrong. (The error may vary from 0 to about $\pm 50^{\circ}\text{C}$ depending on the type of the error)	<ul style="list-style-type: none"> • The thermocouple type selected in MC4 does not correspond with the used thermocouple. • The selected Reference Junction mode is not in accordance with the used wiring. • Extension or compensation cable type or connections are incorrect. • The polarity of the cables are incorrect.
MC4 (or the instrument under test) displays random readings during thermocouple measurement.	<ul style="list-style-type: none"> • Incorrect connections. • The wiring is broken. • Interference from a mobile phone or a radio transmitter affects the measurement.
MC4 displays unstable readings during thermocouple simulation.	<ul style="list-style-type: none"> • The instrument to be calibrated uses voltage pulses to detect an open sensor. When MC4 detects these pulses, it tries to compensate for them, which causes the unstable output. Prevent these pulses for the time of calibration. Refer to the service manual of the instrument to be calibrated on how to prevent these open sensor detection pulses.

Resistance and RTD Measurement, Connections

The two main problems in resistance and RTD measurement are the effects of wiring resistances and thermovoltages in the resistance measurement circuit. If possible, use 4-wire connection to eliminate the effect of wiring resistance. The special resistance measurement sequence of MC4 eliminates the thermovoltages of the resistance measurement circuit.

MC4 continuously checks the connection type during resistance and RTD measurement. The found connection type is displayed on the resistance or RTD measurement window.

4-wire System



When 4-wire system is used, MC4 displays the symbol shown on the left.

MC4 sources current through the resistor from the two left side terminals. MC4 measures the voltage drop across the resistor from the two right side terminals. The 4-wire method gives the resistance between the terminals of the resistor, it is insensitive to the resistance of the connection wires.

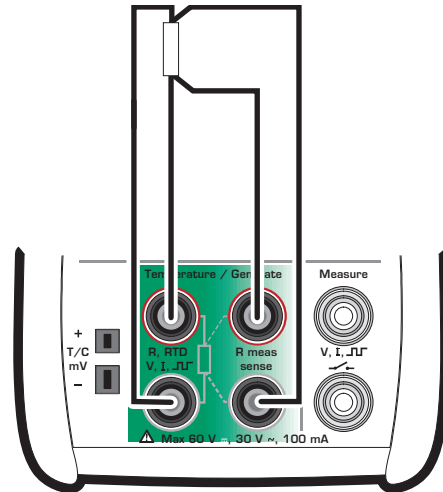

3-wire System



When 3-wire system is used, MC4 displays the symbol shown on the left.

MC4 sources current through the resistor from the two left side terminals. MC4 measures the voltage drop across the entire current loop and across the low side connection wire. If both left side connection wires are identical, MC4 can compensate for the resistance of the connection wires.

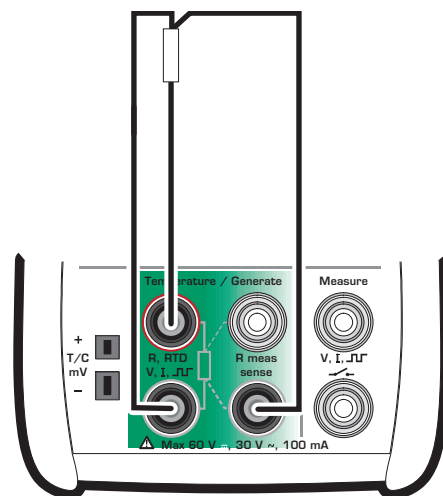

Using a Compensation Loop



When the compensation loop wiring system is used, MC4 displays the symbol shown on the left.

MC4 sources current through the resistor and the compensation loop from the two left side terminals. MC4 measures the voltage drop across the entire current loop and across the compensation loop.

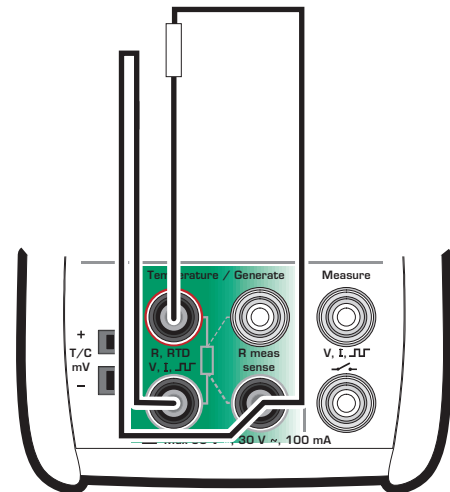

If the compensation loop and the connection wires of the resistor are identical, MC4 can compensate for the resistance of the connection wires.

2-wire System



When 2-wire system is used, MC4 displays the symbol shown on the left.

Calibrator sources current through the resistor and measures the voltage drop across the same terminals.

The result is acceptable, if the resistance of the connection wires is significantly smaller than actual measured resistance.

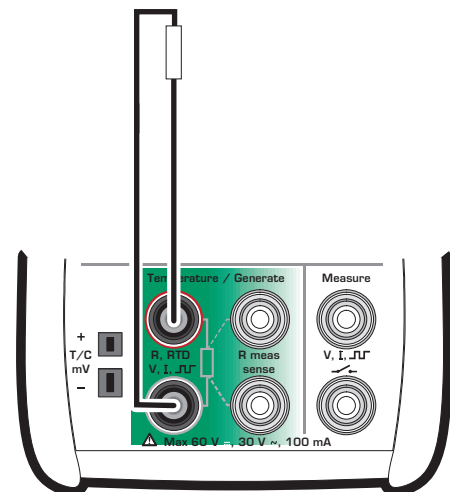

Hint!

To minimize the effect of connection wires in 2-wire system measurement, use deviation measurement presented on **page 87** as follows:

Measure the resistance of only the connection wires. Set the measured value as the **Measure Deviation from** value. Then the resistance of the connection wires is subtracted from the total resistance and the displayed deviation value is closer to the resistance meant to be measured.

Current Measurement Parallel to a Test Diode, Connections

The impedance of MC4's milliampere input is low enough to enable current measurement parallel to a test diode in a 20 mA circuit.

Plus Side Test Diode Connections:

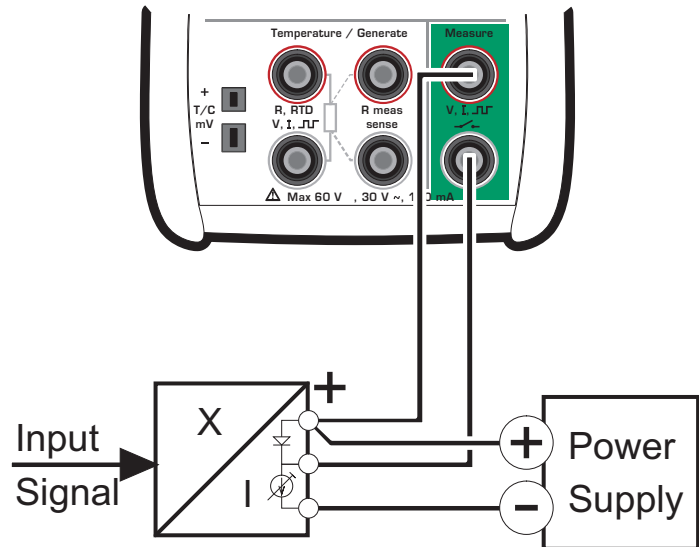

Minus Side Test Diode Connections:

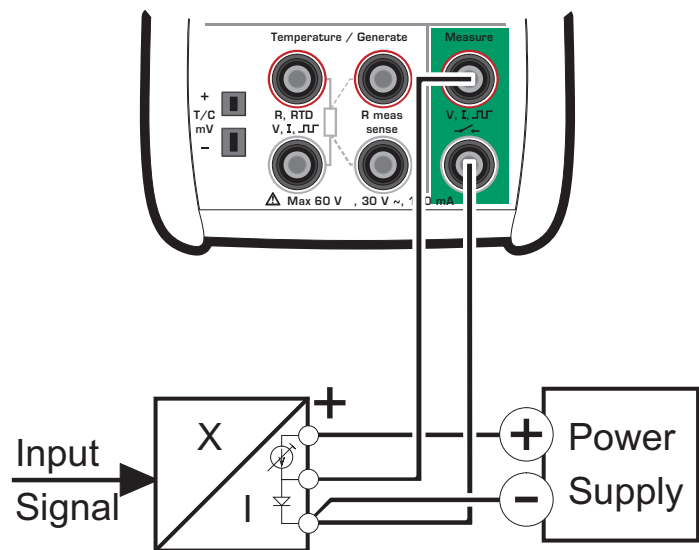

MC4 parallels the test diode of the transmitter and measures the externally supplied output current of the transmitter.

Notes.

In higher temperatures: The leakage of the diode in the instrument may affect the accuracy.

Parallel Functions in MC4

This chapter explains what kind of simultaneous duties MC4 can do.

All of the following tasks may run independently, but the window settings decide what is shown:

- Each internal or external **pressure measurement** runs independently.
- One electrical measurement in the **Measure** terminals.
- One electrical measurement and one electrical generation/simulation in the **Temperature / Generate** terminals.

Additionally, all of the connectors on the left side of MC4 may have an independent task.

Notes.

The Barometric module can always be used for pressure type conversion, even if it is already active in any window.

See **Part D, Calibration**, chapter **Supported Input/Output Signal Combinations** for additional info on which Functions may simultaneously be active during instrument calibration .

(Empty)

Calibration

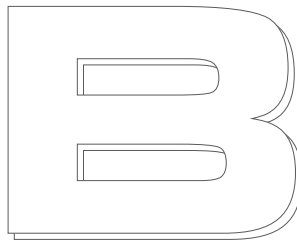
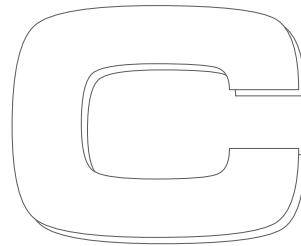

Things discussed in Part D:

- General presentation of what calibration is and the phases of a typical calibration procedure.
- A description of a calibration procedure using MC4.
- Some application examples on how to perform the calibration of certain instruments.
- Creating, editing and deleting Instruments.
- Viewing calibration results.

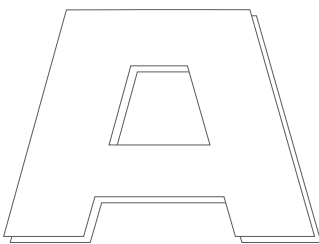

General

MC4 supports **stand-alone calibration** and **off-line calibration**. The following list briefly describes these methods:

- In stand-alone calibration, all instrument and calibration result data is stored in MC4's memory. No external calibration database is used.
- In off-line calibration (sometimes also called batch calibration), the instrument data is downloaded from a calibration software. The calibration is done just as in stand-alone calibration, but instrument data and calibration procedures are downloaded from a calibration software and calibration results are uploaded to the calibration software.

Phases of Instrument Calibration

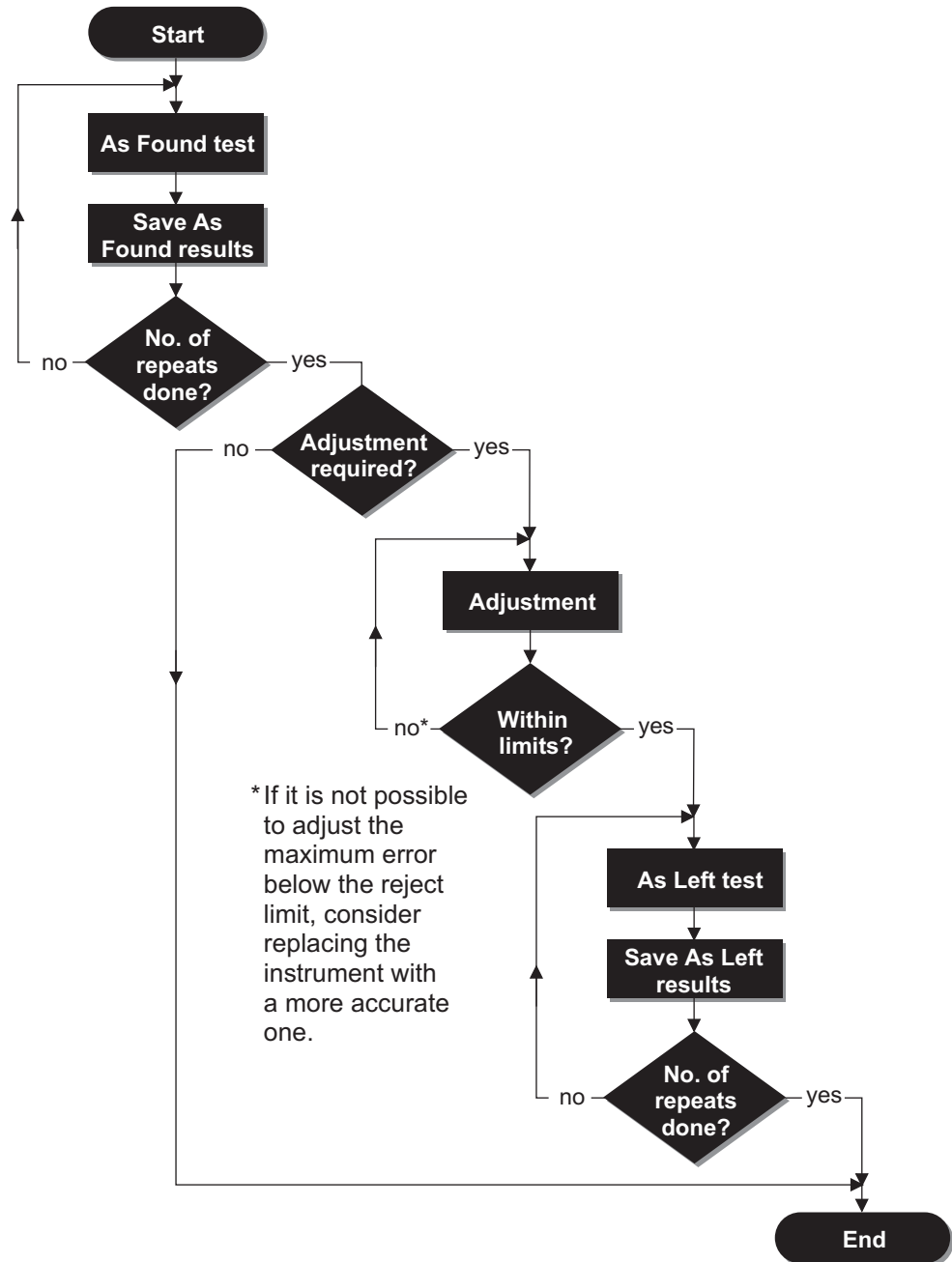

The picture gives a general view of the phases in a typical calibration procedure.

As Found Calibration

The As Found calibration documents the state of the instrument before carrying out any adjustments. The calibration specifies the amount of drift in the instrument during the calibration period.

Below is an example of an error graph. It is used for evaluating the instrument.

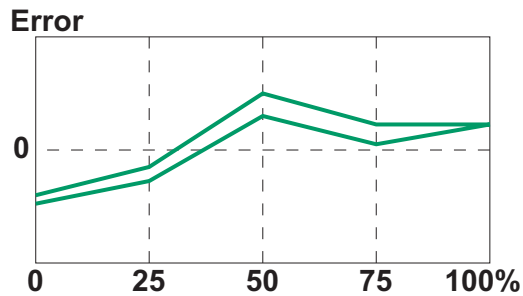

More of error calculation in chapter **Error Calculation Formulas** on page 181.

Adjustment

If the found error is outside acceptable limits (reject limits), the instrument needs adjustment. Activate one of MC4's error display modes to help you minimize the error (see chapter **Tools Menu** in part B).

Use the instrument's ZERO adjustment at lower end of the range. Adjust the higher end of the range with the instrument's SPAN adjustment. The two adjustment points do not necessarily need to be the end points of the instrument range. You may want to use other points to optimize the calibration at the most important part of the range. Note, however, that if the points are very close to each other, the error at other points of the range may be quite big (see **As Left Calibration** on next page).

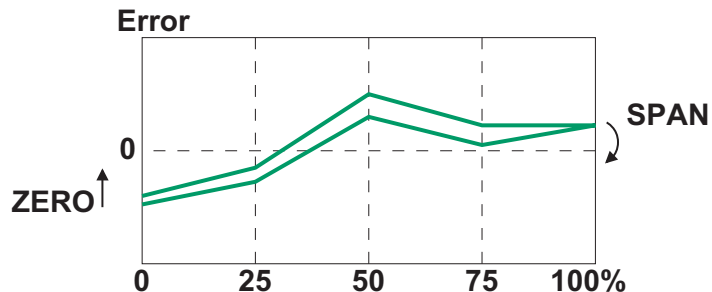

As Left Calibration

The As Left calibration document the state of the instrument after the possible adjustment. If the As Found calibration proves to be good and no adjustment is needed, you may omit the As Left calibration.

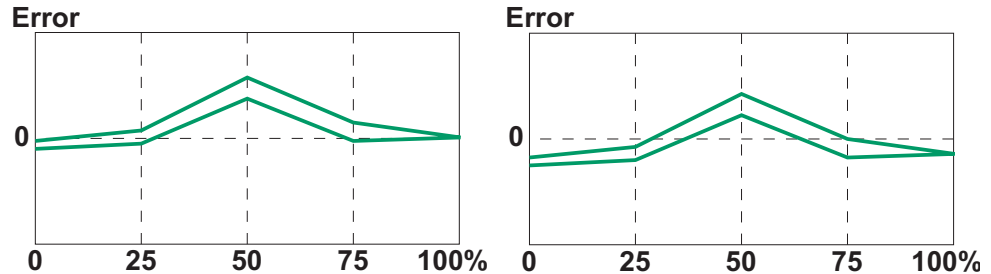

The pictures above display different As Left calibration graphs after two different kinds of adjustments.

In the leftmost picture, the error is minimized at the end points of the instrument range. This results in a relatively notable error in the middle of the span. If the middle of the span is the area, where the measurement is usually situated, then this method is not recommended.

The rightmost picture displays the error graph when the maximum error is minimized by "lowering the graph". As a result, the error minimum is at approx. 30 % and 70 % of the span.

Note that these adjustment strategies are just examples. There is an unlimited amount of "correct" ways to adjust an instrument.

Supported Input/Output Signal Combinations

Consider the type of your instrument before doing a calibration:

- Which Function (and possible additional settings) is needed in MC4 to determine the instrument's **input**? Select a corresponding **column** from the table below.
- Which Function (and possible additional settings) is needed in MC4 to determine the instrument's **output**? Select a corresponding **row** from the table below.

The symbol in the cell, where the column and row crosses, defines whether the combination is supported (●) or not (-).

Legend: ● = Supported combination
 - = Not supported combination

Note:

- Functions **"No Function"** and **"Manually Keyed Value"** have no limitations.
- Barometric Module can be used on both windows, e.g. combined to a gauge module in both windows (to display absolute pressure).

	Press. meas.	Measure Section	Temperature/Generate Section																			
			Measurements								Generations/Simulations											
	Internal Pressure Module	External Pressure Module	Current Meas., Supply On/Off	Voltage Measurement	Frequency Measurement	Pulse Counting	Switch	Resistance Measurement	RTD Sensor Measurement	Low Voltage Measurement	T/C Sensor Measurement, RJ Mode other than "External RTD"	T/C Sensor Measurement, RJ Mode: "External RTD"	Current Source or Sink - With External Supply, Sink	Voltage Generation	Frequency Generation	Pulse Generation	Resistance Simulation	RTD Sensor Simulation	Low Voltage Generation	T/C Sensor Simulation, RJ Mode other than "External RTD"	T/C Sensor Simulation, RJ Mode: "External RTD"	
Internal Pressure Module	-	●	●	●	●	●	●	●	●	●	●	●	●	●	●	●	●	●	●	●	●	●
External Pressure Module	●	-	●	●	●	●	●	●	●	●	●	●	●	●	●	●	●	●	●	●	●	●
Current Meas., Supply On/Off	●	●	-	-	-	-	-	●	●	●	●	●	●	●	●	●	●	●	●	●	●	●
Voltage Measurement	●	●	-	-	-	-	-	●	●	●	●	●	●	●	●	●	●	●	●	●	●	●
Frequency Measurement	●	●	-	-	-	-	-	●	●	●	●	●	●	●	●	●	●	●	●	●	●	●
Pulse Counting	●	●	-	-	-	-	-	●	●	●	●	●	●	●	●	●	●	●	●	●	●	●
Switch	●	●	-	-	-	-	-	●	●	●	●	●	●	●	●	●	●	●	●	●	●	●
Resistance Measurement	●	●	●	●	●	●	●	-	-	●	●	-	-	-	-	-	-	-	-	●	●	-
RTD Sensor Measurement	●	●	●	●	●	●	●	-	-	●	●	-	-	-	-	-	-	-	-	●	●	-
Low Voltage Measurement	●	●	●	●	●	●	●	●	●	-	●	-	-	●	●	●	●	●	●	-	●	-
T/C Sensor Measurement, RJ Mode other than "External RTD"	●	●	●	●	●	●	●	●	●	-	-	-	-	●	●	●	●	●	●	-	●	-
T/C Sensor Measurement, RJ Mode: "External RTD"	●	●	●	●	●	●	●	-	-	-	-	-	-	-	-	-	-	-	-	-	-	-
Current Source or Sink - With External Supply, Sink	●	●	●	●	●	●	●	-	-	●	●	-	-	-	-	-	-	-	-	-	-	-
Voltage Generation	●	●	●	●	●	●	●	-	-	●	●	-	-	-	-	-	-	-	-	-	-	-
Frequency Generation	●	●	●	●	●	●	●	-	-	●	●	-	-	-	-	-	-	-	-	-	-	-
Pulse Generation	●	●	●	●	●	●	●	-	-	●	●	-	-	-	-	-	-	-	-	-	-	-
Resistance Simulation	●	●	●	●	●	●	●	-	-	●	●	-	-	-	-	-	-	-	-	-	-	-
RTD Sensor Simulation	●	●	●	●	●	●	●	-	-	●	●	-	-	-	-	-	-	-	-	-	-	-
Low Voltage Generation	●	●	●	●	●	●	●	●	●	-	-	-	-	-	-	-	-	-	-	-	-	-
T/C Sensor Simulation, RJ Mode other than "External RTD"	●	●	●	●	●	●	●	●	●	-	-	-	-	-	-	-	-	-	-	-	-	-
T/C Sensor Simulation, RJ Mode: "External RTD"	●	●	●	●	●	●	●	-	-	-	-	-	-	-	-	-	-	-	-	-	-	-

Note.

See **Part C, Advanced Operation and Configurations**, chapter **Parallel Functions in MC4** for additional info on what kind of simultaneous tasks MC4 is able to do.

About Instrument Calibration

This chapter and its subchapters present a basic approach on how to perform a calibration with existing instrument data. By reading this you will have general overview of a calibration procedure using MC4.

For more detailed information of certain aspects, refer to the following chapters:

- **Examples of Instrument Calibration** on page 135,
- **Instrument List Window Menu** on page 152,
- **Calibration Window Menu** on page 145,
- **Maintaining MC4's Instrument Database** on page 150,
- **How to Create Instruments and Plant Structure Levels** on page 151,
- **Editing Instrument Data** on page 156
- **Viewing Calibration Results** on page 174 and
- **Additional Calibration Related Information** on page 177.

Selecting the Instrument to Be Calibrated

To move from Basic Mode to Instrument Calibration Mode, press **F3/Menu** and select **Instrument Calibration** from the opened menu.

The uppermost row in the opened **Instrument List** displays the name of the current plant structure level. To the left of the name is a chevron "<" and a number (8 in the adjacent example).

The number is the amount of instruments (positions/devices) available on that particular plant structure level.

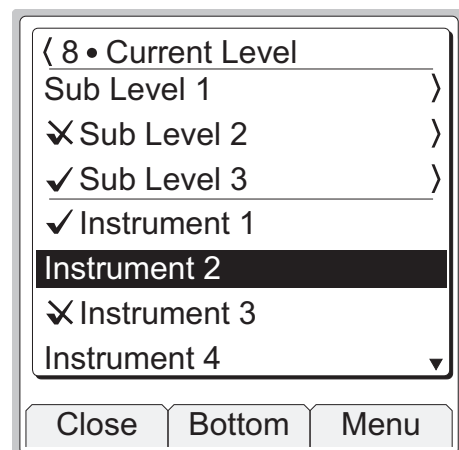

The current plant structure level is followed by names of sub levels (if there are any), then by instrument (positions/devices) belonging to the current plant structure level.

To select an instrument for calibration, use the arrow keys (▲ and ▼) to move the cursor (the inverted text) to the desired instrument. Select the instrument by pressing the ← key. Alternatively, press **F3/Menu** and then **Select** from the opened menu.

If you want to move to another plant structure level, move the cursor to the name of that particular level and press the ← key.

How the instrument is identified in the Instrument List depend on entered instrument data. For more information, see page 157.

A Calibration Procedure Using MC4

When you have selected an instrument for calibration, a window like the leftmost picture below opens.

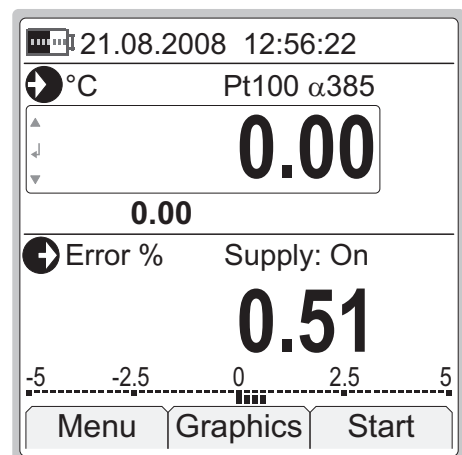
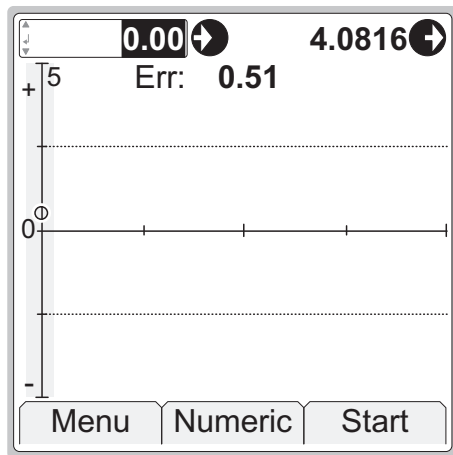

The current **input value** is shown to the left of the ← symbol. The current **output value** is shown to the left of the → symbol. Most of the display area is reserved for an error graph.

If you want to see larger numeric values, press **F2/Numeric**. Then the display looks like the rightmost picture above. The upper window displays the input value and the lower window displays the error numerically and as a bar graph. Return to graphics view by selecting **F2/Graphics**.

Before starting the actual calibration, make sure all your connections are ok and both the input and output is "live" in the calibrator display.

Start the calibration by pressing **F3/Start**. The following paragraphs present the general flow of a calibration run:

1. The instrument's input signal should be set to a value corresponding to the next calibration point. This is done using one of the following methods:
 - When the calibrator is capable of **generating/simulating** the instrument's input signal, MC4 sets the value automatically.
 - If an **external device** (e.g. a pressure controller) generates the input signal, set the target value for the input signal as the external device's set point. MC4 measures the output of the external device, i.e. instrument's input signal.
 - If the input signal is **generated manually** (e.g. a pressure pump) set the input signal into required level. Again, MC4 measures the manually generated signal.
 - Finally, if MC4 is not capable of measuring/generating/simulating the input signal is **manually entered** into MC4.
2. The input and output values should be accepted when they both are stable and the input is close enough to the target value, i.e. calibration point.

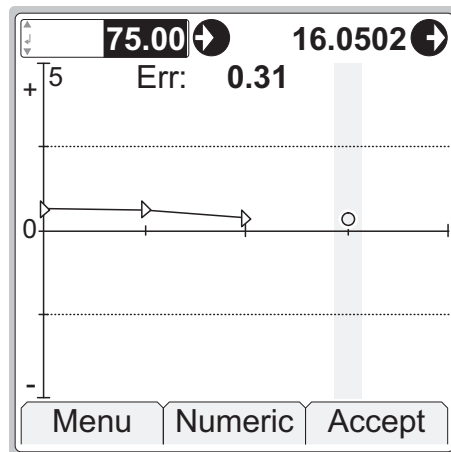

*Calibration under way,
Graphics view selected.
Target value/area for point:
Grey vertical bar*

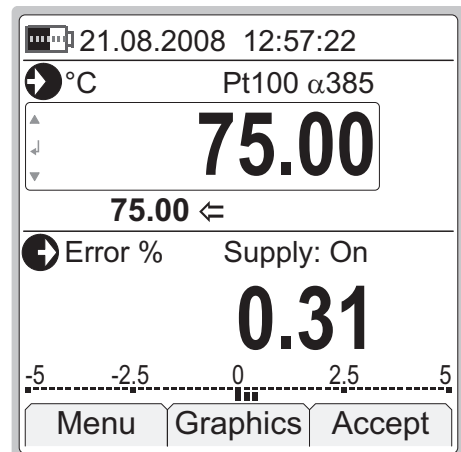

*Calibration under way,
Numeric view selected.
Target value for point:
Number to the left of "←".*

Note that both the graphics view and the numeric view are different for switches. See examples of them in chapter **Electrical Limit Switches** on page 142.

The way MC4 accepts calibration points depend on the Instrument's **Calibration Procedure** settings. Briefly: MC4 can be set to accept current point and advance to next point fully automatically. Optionally, accepting and/or advancing may be set to require user intervention.

More of Calibration Procedure settings in chapter **Procedure Data Page** on page 165.

You can pause a calibration run whenever you want by pressing **F3/Menu**. As long as the menu is open, the calibration is paused. You may also view the calibration window and still keep the calibration paused by selecting the **Pause** option. Then the calibration starts by pressing **F3/Continue**. In the menu, you also have the possibility to, e.g. **Undo** a point or **Skip** a point. More of the menu available in the calibration window can be found in chapter **Calibration Window Menu** on page 145.

- When the calibration run is ready, MC4 opens a window telling whether the calibration was **Passed** or **Failed**. The found **Maximum error** and the **Reject limit** for the calibrated instrument are also shown. Press **F3/Ok** to view the results of the current calibration .

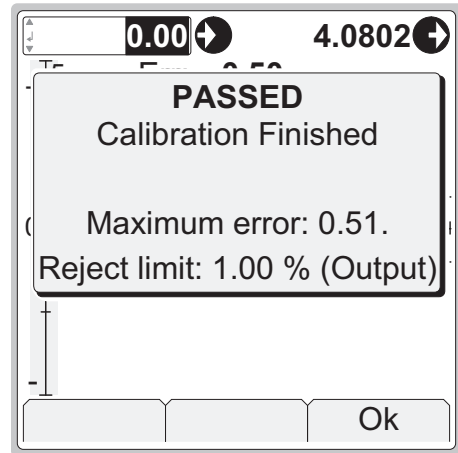

- The result window always opens with the numeric result page open (see leftmost picture below). To see more calibration result related data, press **F2/More**. The second of all in all 3 result pages is the **Calibration Info** page where you are able to enter **Calibrated By** and environment data. See also notes later on in this chapter.

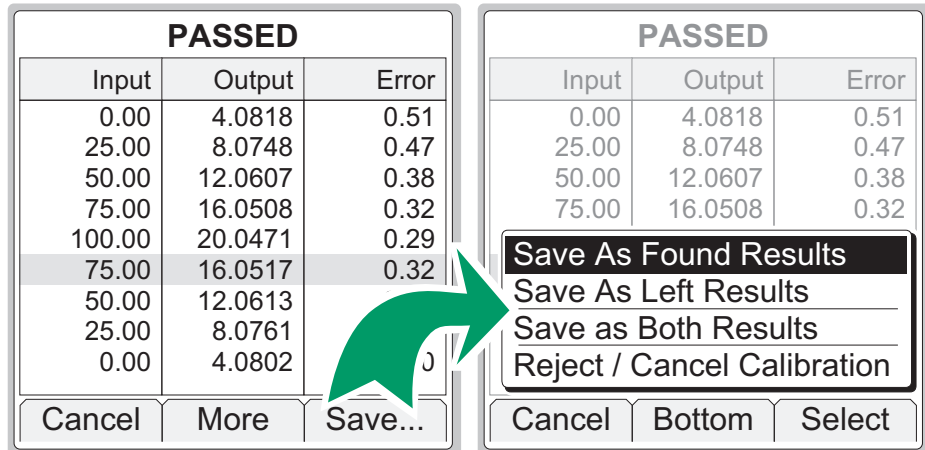

- Save/reject the results by pressing **F3/Save**. Select one of the options in the rightmost picture above.
- After the results are saved/rejected, here are some possibilities of how you may continue:
 - Start another calibration run by pressing **F3/Start**.
 - Adjust the instrument by selecting **F1/Menu, Adjust Instrument**.
 - End the calibration selecting **F1/Menu, Close**.

Examples of Instrument Calibration

The following pages contain a few examples of how to calibrate an instrument using MC4.

When uncertain, consult Part B of this manual for information on how to connect instruments and configure the windows of MC4 to suit the instrument's needs.

The following calibration examples are presented in this manual:

- **Pressure Transmitters** on page 134,
- **Temperature Indicators and Recorders** on page 136,
- **Temperature Sensors** on page 138,
- **Pneumatic Pressure Transmitters and Converters** on page 140 and
- **Electrical Limit Switches** on page 142.

Warning!

Working with pressure instruments can be hazardous. Only qualified personnel may use pressure instruments and pressure sources. See pressure measurement related warnings in Part A of this manual.

Pressure Transmitters

This procedure suits all instruments with a pressure input and any kind of electrical output signal. Both the input and output signal range should be measurable with MC4.

Note.

In order to perform a pressure transmitter calibration, the MC4 at hand needs to have either a suitable internal pressure module or an external pressure module has to be connected to MC4.

Preparations

1. Connect the instrument's input to the selected pressure module (internal or external).
2. Connect a pressure source both to the instrument's input and to the pressure module.
3. Connect the instrument's output signal to appropriate terminals in MC4. If the output signal is current, select whether MC4 provides the supply voltage or not (see Current Measurement in Part B).
4. Select the instrument in MC4 as presented in chapter **Selecting the Instrument to Be Calibrated** on page 129 or create a new instrument as described in chapter **Instrument List Window Menu** on page 152.
5. Test the connections before starting calibration, i.e. see if the input and output signal are "live" in MC4.

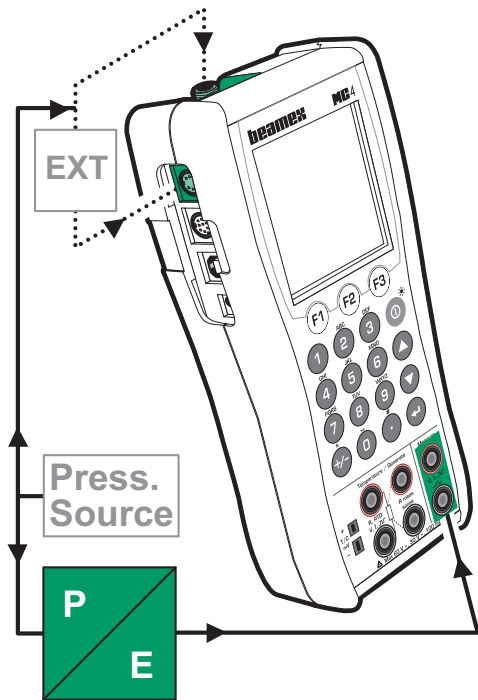

Calibration

1. In the calibration window: press **F3/Start**.
2. Set the pressure using, e.g. a pressure pump. Aim for the calibration point's target value as shown on page 131.
3. How a calibration point is accepted depends on the procedure settings of the instrument at hand:
 - If **Automatic Calibration Point Acceptance** is set (checked), the input and output values of the current point are saved automatically. Automatic acceptance settings are presented in chapters **Procedure Data Page** on page 165 and **Accepting Calibration Points Automatically** on page 178.
 - If **Automatic Calibration Point Acceptance** is not set, accept the point using **F3/Accept** Function Key. Note that this functionality is also available when **Automatic Calibration Point Acceptance** is set. This allows you to save results when the input and/or output signals are permanently unstable.
4. Proceed to next calibration point (step 2) if applicable. When the calibration run is ready, save or reject the results as described in chapter **A Calibration Procedure Using MC4** on page 130.
5. Either do another calibration run, adjust the instrument or end the calibration by selecting **F1/Menu, Close**.

Notes.

For information on how to zero a pressure module, see chapter **Zeroing a Pressure Module During Calibration** on page 180.

For information on how to change pressure module during calibration, see chapter **Changing the Pressure Module During Calibration** on page 179.

Hint!

These instructions can be adapted for any kind of transmitter. Change the input signal connections/settings according to the instrument's input signal. When calibrating another kind of pressure instrument, use this example as the source for the input signal part.

When measuring absolute pressure while using high pressure Pressure Modules, you may enter manual barometric pressure in the window that opens by pressing **F1/Menu, Instrument Input** .

Temperature Indicators and Recorders

This procedure suits temperature indicators/recorders no matter if the sensor is an RTD or a thermocouple. The instrument's input signal is simulated using MC4. The instrument's output (reading) is manually entered into MC4.

Preparations

1. Connect suitable terminals in MC4 to the input connectors of the indicator/recorder.
2. If the sensor to be simulated is a thermocouple, select one of the following reference junction methods:
 - MC4's internal reference junction is used.
 - The reference junction temperature is measured externally using an RTD connected to the RTD terminals.
 - The reference junction temperature is fixed to 0°C.
 - The reference junction temperature is manually entered.

Additional information about Reference Junction compensation methods can be found in chapters **Internal Reference Junction** on page 113 and **External Reference Junction** on page 114.

3. If the sensor to be simulated is an RTD, the used wiring system depends on the instrument to be calibrated. Remember to only use the two leftmost RTD terminals in MC4.
4. Select the instrument in MC4 as presented in chapter **Selecting the Instrument to Be Calibrated** on page 129 or create a new instrument as described in chapter **Instrument List Window Menu** on page 152.
6. Test the connections before starting calibration, i.e. see if the input and output signal are "live" in MC4.

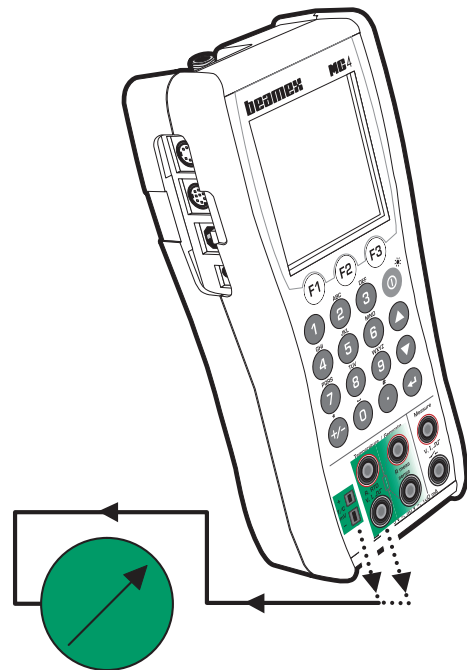

Calibration

1. In the calibration window: press **F3/Start**.
2. Enter the temperature to be simulated There are two different strategies on how to set the temperature:
 - Adjust the simulated value until the reading of the indicator/recorder is exactly the same as the default output value for the current calibration point. This method is useful when calibrating analog indicators/recorders and the input signal can be fine adjusted.
 - Do not adjust the simulated value, but enter the actual reading as the output value. This method suits indicators with digital display. It is also handy when calibrating other types of indicators/recorders with an input signal that do not support fine adjustment (e.g. pressure indicators).
3. Accept the point using **F3/Accept** Function Key.
4. Proceed to next calibration point (step 2) if applicable. When the calibration run is ready, save or reject the results as described in chapter **A Calibration Procedure Using MC4** on page 130.
5. Either do another calibration run, adjust the instrument or end the calibration by selecting **F1/Menu, Close**.

Hint!

These instructions can be adapted for any kind of indicator/recorder. Change the input signal connections/settings according to the instrument's input signal.

When calibrating a temperature instrument with a detachable sensor (the input signal is simulated with MC4), use this example as the source for the input signal part.

You may set the display resolution for the entered indication/reading in the window that opens by pressing **F1/Menu, Instrument Output** .

Temperature Sensors

This procedure suits temperature sensors no matter if they are RTDs or thermocouples. The sensor's output signal is measured with MC4. The reference temperature is either measured with MC4 or manually entered into MC4. i

When measuring the reference temperature, remember the following conditions:

1. If the sensor to be calibrated is a thermocouple, the reference sensor needs to be an RTD sensor.
2. If the sensor to be calibrated is an RTD sensor, the reference sensor needs to be a thermocouple.

If the conditions are not met, the reading of the reference sensor has to be manually entered into MC4.

Preparations

1. Place the sensor of the instrument and the reference sensor into the calibration bath/dry block. Connect them to suitable terminals in MC4. Select one of the available reference junction methods for the thermocouple:
 - MC4's internal reference junction is used.
 - The reference junction temperature is fixed to 0°C.
 - The reference junction temperature is manually entered.
 - The reference junction temperature is measured externally using an RTD connected to the RTD terminals.

See Part C for additional information concerning the reference junction methods.

2. Select the instrument in MC4 as presented in chapter **Selecting the Instrument to Be Calibrated** on page 129 or create a new instrument as described in chapter **Instrument List Window Menu** on page 152.
3. Test the connections before starting calibration, i.e. see if the input and output signal are "live" in MC4.

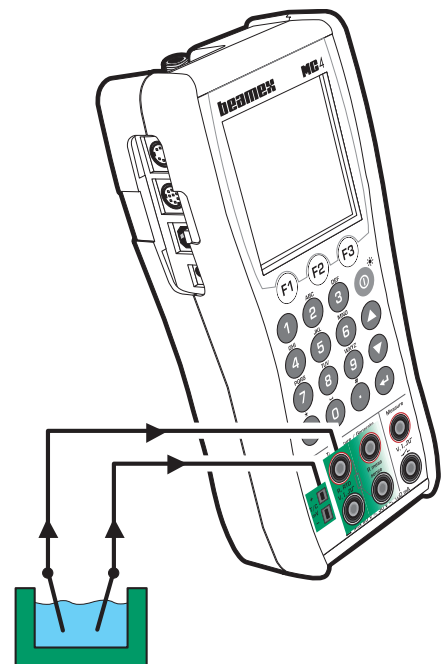

Calibration

1. In the calibration window: press **F3/Start**.
2. Set the temperature of the bath/dry block to the required calibration point. Wait until the temperature stabilizes.
3. If the temperature of the reference sensor is entered manually, enter the value.
4. How a calibration point is accepted depends on the procedure settings of the instrument at hand:
 - If **Automatic Calibration Point Acceptance** is set (checked) and applicable, the input and output values of the current point are saved automatically. Automatic acceptance settings are presented in chapters **Procedure Data Page** on page 165 and **Accepting Calibration Points Automatically** on page 178.
 - If **Automatic Calibration Point Acceptance** is not set/applicable, accept the point using **F3/Accept** Function Key. Note that this functionality is also available when **Automatic Calibration Point Acceptance** is set. This allows you to save results when the input and/or output signals are permanently unstable.
5. Proceed to next calibration point (step 2) if applicable. When the calibration run is ready, save or reject the results as described in chapter **A Calibration Procedure Using MC4** on page 130.
6. Either do another calibration run, adjust the instrument or end the calibration by selecting **F1/Menu, Close**.

Pneumatic Pressure Transmitters and Converters

This procedure suits all instruments with both a pressure input and a pressure output signal. Both the input and output signal range should be measurable with MC4.

To be able to perform the calibration, an internal pressure module need to be installed and an external pressure module need also be connected to MC4. The example picture below has the instrument's input connected to the internal pressure module and the instrument's output connected to the external pressure module. The pressure modules may also be used the other way. All that matters is that the pressure module's span and accuracy suits the pressure signal.

Preparations

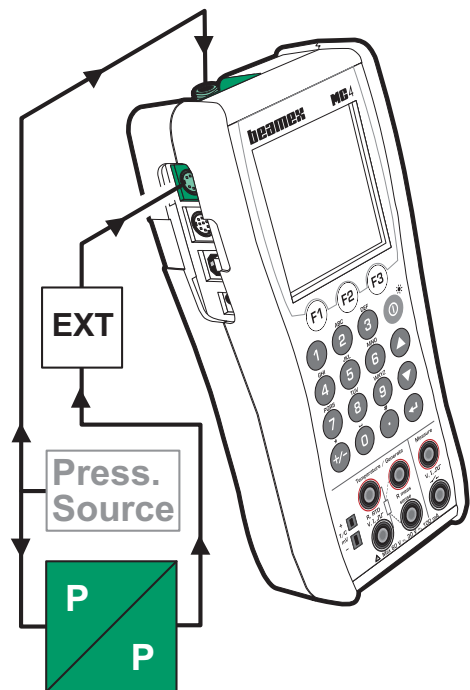

1. Connect the instrument's input to the selected pressure module (internal or external).
2. Connect a pressure source both to the instrument's input and to the pressure module.
3. Connect the instrument's output to the selected pressure module (internal or external).
4. Select the instrument in MC4 as presented in chapter **Selecting the Instrument to Be Calibrated** on page 129 or create a new instrument as described in chapter **Instrument List Window Menu** on page 152.
5. Test the connections before starting calibration, i.e. see if the input and output signal are "live" in MC4.



Calibration

1. In the calibration window: press **F3/Start**.
2. Set the pressure using, e.g. a pressure pump. Aim for the calibration point's target value as shown on page 131.
3. How a calibration point is accepted depends on the procedure settings of the instrument at hand:
 - If **Automatic Calibration Point Acceptance** is set (checked), the input and output values of the current point are saved automatically. Automatic acceptance settings are presented in chapters **Procedure Data Page** on page 165 and **Accepting Calibration Points Automatically** on page 178.
 - If **Automatic Calibration Point Acceptance** is not set, accept the point using **F3/Accept** Function Key. Note that this functionality is also available when **Automatic Calibration Point Acceptance** is set. This allows you to save results when the input and/or output signals are permanently unstable.
4. Proceed to next calibration point (step 2) if applicable. When the calibration run is ready, save or reject the results as described in chapter **A Calibration Procedure Using MC4** on page 130.
5. Either do another calibration run, adjust the instrument or end the calibration by selecting **F1/Menu, Close**.

Hint!

When measuring absolute pressure while using high pressure Pressure Modules, you may enter manual barometric pressure in the window that opens by pressing **F1/Menu, Instrument Input**  or **F1/Menu, Instrument Output** . Then you may select "**Absolute**" as the pressure type and MC4 uses the manually entered barometric pressure to display the measured gauge pressure as absolute pressure.

Electrical Limit Switches

This procedure suits limit switches with an electrical input. MC4 generates the switch's input signal and measures the switch's state.

Preparations

1. Connect the instrument's input to MC4's output terminals (see picture).
2. Connect the switch's output to the measuring terminals in MC4.
3. Select the instrument in MC4 as presented in chapter **Selecting the Instrument to Be Calibrated** on page 129 or create a new instrument as described in chapter **Instrument List Window Menu** on page 152.
4. Test the connections before starting calibration, i.e. see if the input and output signal are "live" in MC4.

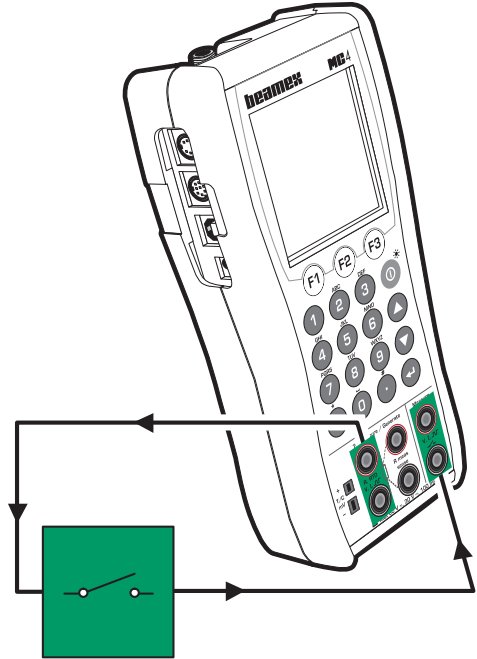

Calibration

1. In the calibration window: press **F3/Start**.
2. MC4 does a **Prescan** if it is enabled. During the prescan, MC4 searches for approximate values for actuating and deactuating point. This speeds up the final test without sacrificing accuracy. The defined scan range is used during prescan. After a successful prescan MC4 may be set to use a narrower scan range based on acquired approximate values for actuating and deactuating point. The prescan test is done only once in a calibration.
 - By default, the Prescan is set to on. If you do not want MC4 to perform a prescan, disable it by editing the instrument's Procedure data (uncheck **Use Prescan** field). When Prescan is set to off, MC4 uses the whole scan range also during the actual test. See also notes further on.

3. The actual test is done automatically: MC4 slowly increases the input signal until the switch actuates and continues by decreasing the input signal until the switch deactuates. MC5's screen displays the obtained data as the test advances.
4. How the results are accepted depends on the procedure settings of the instrument at hand:
 - If **Automatic Calibration Point Acceptance** is set (checked), the actuating and deactuating points of the current switch cycle are saved automatically. Automatic acceptance settings are presented in chapters **Procedure Data Page** on page 165 and **Accepting Calibration Points Automatically** on page 178.
 - If **Automatic Calibration Point Acceptance** is not set, accept the point using **F3/Accept** Function Key.
5. A calibration run can include several switch cycles. The amount of switch cycles is defined among the instrument's procedure data. As long as more switch cycles need to be done, MC4 automatically starts a new cycle (step 3).
6. When all switch cycles are done, i.e. the calibration run is ready, save or reject the results as described in chapter **A Calibration Procedure Using MC4** on page 130.
7. Either do another calibration run, adjust the instrument or end the calibration by selecting **F1/Menu, Close**.

The pictures below present the calibration windows Graphics view (left) and Numeric view (right) for switches:

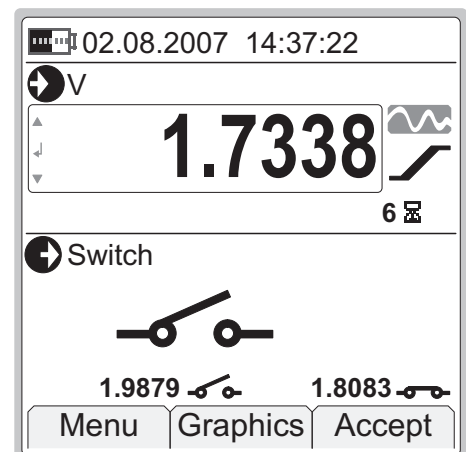
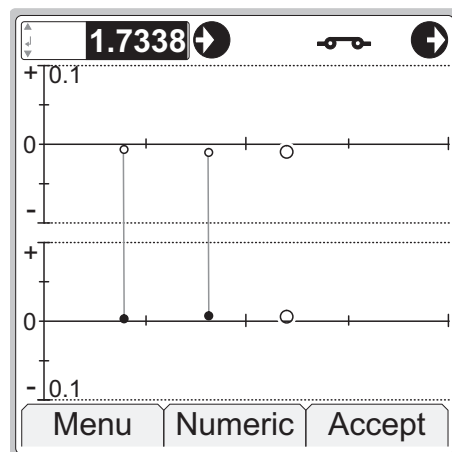

In Graphics view there are two graphs. The upper one shows the error for the actuating point and the lower one the error of the deactuating point. The Numeric view displays the measured actuating point and deactuating point just above the Function Keys.

Note.

If the prescan stops and displays an error message, try widening the scan range(s). It is also advisable to have the scan range(s) symmetrical in relation to the actuation/deactuation points. Also check the **Step response wait** setting among calibration procedure data. For more information of **Step response wait** field, see page 168.

Hint!

These instructions can be adapted for any kind of switch. Change the input signal connections/settings according to the instrument's input signal.

When calibrating an electrical instrument and the input signal is generated with MC4, use this example as the source for the input signal part.

Calibration Window Menu

This section presents the menus available in the calibration window.

Menu When Calibration is NOT Started

The following menu options are available when the calibration window is open, but a calibration is not started, i.e. the **F3/Start** Function Key is still visible.

MENU ITEM	DESCRIPTION
Close	Allows you to close the calibration window and return to the Plant Structure window.
Calibration Information	Displays calibration related information on two pages. The displayed information consists of error calculation data, input and output Function and range data and instrument identification data (Position ID and Function Name). Switch between pages using the F2/More Function Key.
Adjust Instrument	Opens the calibration window with added functionality helping you adjust the instrument. Note that Function Key F3 allows you to jump between instrument input range's minimum and maximum. This feature is useful when the instrument's input signal is generated/simulated with MC4. <i>Continues on next page...</i>



MENU ITEM <i>(cont.)</i>	DESCRIPTION
Edit Instrument	Opens the instrument window where you may edit instrument data. More of instrument data in chapter Editing Instrument Data on page 156.
Instrument Input ▶	Allows you to check the instrument's input and enter/edit data related to the selected Function. More details in chapter Extra Information Saved With Calibration Point Data on page 177. Instrument Input window also has a Tools submenu available. The contents of the Tools menu is described in chapter Tools Submenu on page 149.
Instrument Output ▶	Allows you to check the instrument's output and enter/edit data related to the selected Function. More details in chapter Extra Information Saved With Calibration Point Data on page 177. Instrument Output window also has a Tools submenu available. The contents of the Tools menu is described in chapter Tools Submenu on page 149.
Result History	Visible only when saved calibration data exists for the selected instrument in MC4's memory. More of viewing results in chapter Viewing Calibration Results on page 174.

Menu When a Calibration is Running



The following menu options are available when the calibration window is open and a calibration is running.

Note that the calibration is paused as long as this menu is open. Once the menu is closed, the calibration continues, unless the **Pause** option was selected..

MENU ITEM	DESCRIPTION
Reject/Cancel Calibration	Allows you to close the calibration window and return to the Plant Structure window without saving any calibration results.
Save Incomplete Calibration	Allows you to save the results of a partly done calibration. When selected, the result window opens. Use the F3/Save Function Key to save the results. After saving you return to the calibration window and may either start a new calibration run or close the calibration window.
Calibration Information	Displays calibration related information on two pages. The displayed information consists of error calculation data, input and output Function and range data and instrument identification data (Position ID and Function Name). Switch between pages using the F2/More Function Key.
Pause	Keeps the calibration paused although the menu is closed. When selected, you may continue using F3/Continue Function Key.
Undo Point	Allows you to undo previous calibration point. Available only when there are previously accepted calibration points.
Skip Point	Allows you to skip current calibration point. Advances to the next point (if applicable) without saving the results of current point. <i>Continues on next page...</i>

MENU ITEM <i>(cont.)</i>	DESCRIPTION
<p>Instrument Input</p> 	<p>Allows you to check the instrument's input and enter/edit data related to the selected Function. More details in chapter Extra Information Saved With Calibration Point Data on page 177.</p> <p>Instrument Input window also has a Tools submenu available. The contents of the Tools menu is described in chapter Tools Submenu on page 149.</p>
<p>Instrument Output</p> 	<p>Allows you to check the instrument's output and enter/edit data related to the selected Function. More details in chapter Extra Information Saved With Calibration Point Data on page 177.</p> <p>Instrument Output window also has a Tools submenu available. The contents of the Tools menu is described in chapter Tools Submenu on page 149.</p>
<p>Result History</p>	<p>Visible only when saved calibration data exists for the selected instrument in MC4's memory. More of viewing results in chapter Viewing Calibration Results on page 174.</p>

Tools Submenu

The contents of the Tools submenu opening from the calibration window menu's **Instrument Input**  and **Instrument Output**  options vary depending on the Function use for the input/output.

Full info of Basic State's Tools menu can be found in part B, chapter Tools Menu on **page 67**. All of the following menu items also have links to additional information found in this manual.

MENU ITEM	DESCRIPTION
Function Info	Visible unless the Function is set to "No Function". More information on Function Info is in chapter Function Info on page 68 .
Change Pressure Module	Visible for pressure measurement Functions only. Allows you to change the pressure module during calibration. More info on changing pressure Modules is in chapter Changing the Pressure Module During Calibration on page 179.
Alarms	Visible for measurement Functions only. More info on Alarm settings is in chapter Alarms on page 69 .
Damping	Visible for measurement Functions only. More info on Damping settings is in chapter Damping on page 70 .
Leak / Stability Test	Visible for measurement Functions only. More info on Leak/Stability Test is in chapter Leak/Stability Test on page 71 .
Display Mode / Specials	Visible for instrument input functions if they are either measurement or generation Functions. More info on Display Mode / Specials is in chapter Display Mode and Special Measurements on page 81 .

Note.

The following Tools submenu items have additional conditions as to when they are visible: **Damping**, **Leak / Stability Test** and **Display Mode / Specials** are available only **before** a calibration is started.

Maintaining MC4's Instrument Database

MC4 allows you to create a plant structure with instruments without any limitations except the available memory. The plant structure and its instruments are together saved MC4's instrument database.

When you move from Basic Mode to Instrument Calibration Mode (Menu commands starting from Basic Mode: **F3/Menu, Instrument Calibration**), the instrument list window opens allowing you view the instrument database.

As explained in chapter **Selecting the Instrument to Be Calibrated** on page 129, the instrument list window's uppermost row displays the name of the current plant structure level. Following rows have names of plant structure sub levels (if there are any), and then instruments (positions/devices) belonging to the current plant structure level.

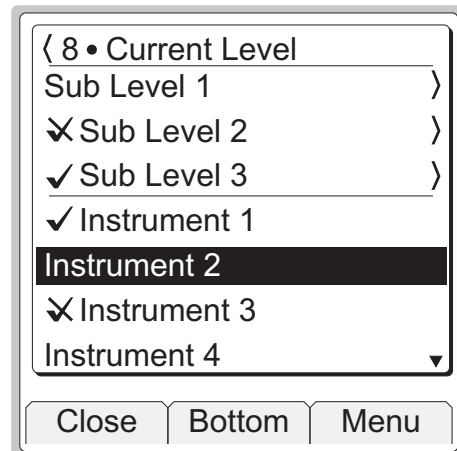

The meaning of check symbols preceding plant structure level names and instrument names are as follows:

For instruments:

- ✓ if a calibration is done and it passed.
- ✗ if a calibration is done and it failed.

For plant structure levels:

- ✓ if all instruments at that particular level (and possible sub levels) are calibrated and passed the calibration.
- ✗ if one of the instruments at that particular level (and possible sub levels) has a failed calibration. Others may have passed calibration or may not have yet been calibrated.

How to Browse Through Instrument List Window

Using the arrow keys (▲ and ▼) to move the cursor is a slow way of browsing through long instrument lists. The following list presents utilities that makes the browsing faster:

- When not at the bottom of the list, Function Key **F3/Bottom**, jumps to the bottom of the list. After that, the Function Key changes to **F3/Top**.
- Scroll one page **down** a list using the decimal point key (◻)
- Scroll one page **up** a list using the +/- key (⊕)
- You can quickly search for items starting with a certain letter by pressing the appropriate numeric keys. Refer to letters above each numeric key.

How to Create Instruments and Plant Structure Levels

The plant structure and instruments may be downloaded from a calibration software (e.g. CMX Calibration Maintenance Management Software).

Optionally they can be created manually by using the tools available in the instrument list window's menu. The menu opens from Function Key **F3**. More of the Instrument List Window's Menu in the next chapter.

Instrument List Window Menu

Many of the instrument list window's menu items have dual functionality. Which functionality is active depends on what is highlighted in the instrument list window.

The two important options in this menu are the **Create New** option and **Management** option. The first one allows you to **add new instruments** and plant structure branches. The latter includes a sub-menu for **deleting instruments**, **plant structure branches** and **calibration results**.

MENU ITEM	DESCRIPTION
Select	<p>If a plant structure level is highlighted, the level is selected for viewing.</p> <p>If an instrument is highlighted, the calibration window opens and you may calibrate the selected instrument</p> <p>Note that you do not necessarily need to use this menu option. Pressing Enter (↵) in the instrument list window does the same thing.</p>
Details	<p>If a plant structure level is highlighted, the location of the level is shown by displaying a list (path) of all higher levels. You may also add a note for the selected plant structure level.</p> <p>If an instrument is highlighted, some basic instrument data is shown. Among the data there is the selected MC4 Function for the instrument's input and output.</p> <p>By pressing F2/More, another page opens displaying the instrument's location, just as was shown for plant structure levels.</p>
Result History	<p>Visible only when saved calibration data exists for the selected instrument in MC4's memory. More of viewing results in chapter Viewing Calibration Results on page 174.</p> <p style="text-align: right;"><i>Continues on next page...</i></p>

MENU ITEM <i>(cont.)</i>	DESCRIPTION
Management	<p>This option opens a submenu with the following options:</p> <ul style="list-style-type: none"> • Cut allows you to cut an instrument or a plant structure level including all its contents for transferring it/them to another location in the plan structure. • Paste. Visible only after cut was selected. Pastes the cut instrument or plant structure branch to another location. • Delete Results. Visible for instruments only. Deletes the calibration results of highlighted instrument. • Delete. If an instrument was highlighted, the instrument and its results are deleted. If a plant structure level was highlighted, deletes all the contents of that particular plant structure branch. • Rename. Visible for plant structure levels only. Allows you to rename the highlighted plant structure level. • Delete All Instruments. Deletes all instruments and their possible results found in MC4's memory. • Delete All Results. Deletes the calibration results of all instruments found in MC4's memory. <p>See also chapter Deleting Calibration Results on page 176.</p> <p style="text-align: right;"><i>Continues on next page...</i></p>

MENU ITEM <i>(cont.)</i>	DESCRIPTION
<p>Create New</p>	<p>A submenu opens with the following options:</p> <ul style="list-style-type: none"> • Create New Instrument, which opens the instrument data windows for adding a new instrument. More of all instrument data windows and the fields they contain in chapter Editing Instrument Data on page 156. See also notes at the end of this chapter. • Create New Branch, which opens a window where you may enter the name of the new plant structure level and write some notes describing it. The name of the new branch has to be unique.
<p>Calibration Mode Settings</p>	<p>This option opens a window where you can edit general calibration related settings:</p> <ul style="list-style-type: none"> • Environment Pressure Unit. Allows you to select a unit for the environment pressure that suits your needs. • Error Graph ± Scaling. With this setting you can define general "zoom" of the calibration window's graph. The reference is the reject error limit. The default value is ±5 times larger graph than what is the instrument's reject error limit. • Allow 'Save as Both' for Saving Calibration Results. Depending on your company policy you may or may not allow saving the results of one successful calibration Both as As Found and as As Left. Check or uncheck this option according to you company policy.

Notes.

When creating a new instrument, MC4 takes the Input and Output Functions based on Functions active in Basic Mode's two windows.

When an instrument to be added is similar to an instrument already existing in MC4's memory, here's a method for adding it quickly:

1. Locate the already existing and similar instrument from MC4's instrument list.
2. Select the instrument for calibration.
3. Do not start the calibration but edit the instrument data. (Select: **F1/Menu, Edit Instrument**)
4. Change the Position ID / Position Name / Device ID and Serial Number fields according to your needs. See **Position Data Page** on page 157 and **Device Data Page** on page 158.
5. Save a copy of the instrument (Menu commands: **F3/Close, Save a Copy**). Note that possible calibration result data is not copied, but stays linked to the original instrument.

The available free memory defines how many instruments may be saved. If there is not enough memory left to create an instrument, MC4 displays an error message suggesting that you first free some memory and then retry.

Editing Instrument Data

This chapter and its subchapters present all fields related to instruments saved in MC4's memory. The fields are available when adding a new instrument and when editing a new instrument.

To create a **new instrument**, go to the Instrument List Window. Press **F3/Menu, Create New**

To edit an **existing instrument**, again go to the Instrument List Window. Select the instrument by pressing the Enter key (↵) or **F3/Menu, Select**. The calibration window opens. Do not start the calibration but press **F1/Menu, Edit Instrument**.

The instrument data window always opens with the Position data page shown. See leftmost picture below.

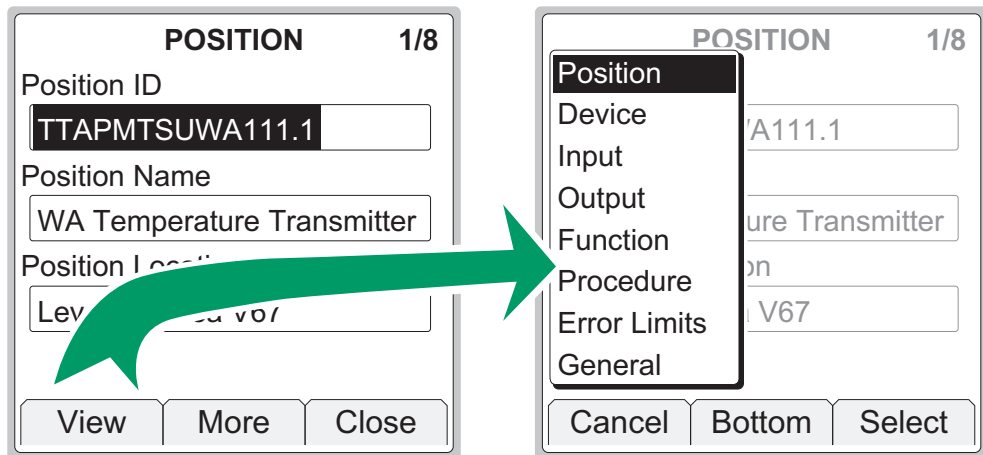

You may move from one data page to another by using either the **F2/More** Function Key or by selecting the **F1/View** Function Key. In the latter case a list of data pages open. Scroll the list using the up and down arrow keys (▲ and ▼) and select a data page with the Enter Key (↵).

Notes.

If you edit an instrument in MC4 and it was originally sent from a calibration software, the software notices the difference(s) when you upload the results. Then, depending on your user rights in the software, you are either allowed to save the results together with updated instrument data or you are refused to save anything. So, if you edit instrument data in MC4, make sure you have the rights to upload edited instrument data.

Text fields in MC4 have no limitation on the length of the text/ID. Take however into consideration, the possible limitations that your calibration database software may have.

Position Data Page

Position related data.

FIELD	DESCRIPTION
Position ID	Position ID is the field, that identifies an instrument position (tag), e.g. PT101.5
Position Name	A text field for giving a descriptive name to the position, e.g. "Pressure Transmitter #5 at reactor #101".
Position Location	A text field for describing the location of the position, e.g. "This position located on top of reactor 101. Level 10.2"

What identifies the instrument in MC4's instrument list.

MC4's instrument list displays one of the following fields/text in the instrument list. The list is hierarchical, i.e. the uppermost is shown if it is not empty. The last text is shown if all of the previously mentioned fields are empty:

1. **Position ID** (found among position data)
2. **Position Name** (found among position data)
3. **Device ID** (found among device data)
4. **Serial number** (found among device data)
5. **(no name)**

Device Data Page

Device related data.

FIELD	DESCRIPTION
Device ID	Device ID is the field, that identifies an instrument.
Serial Number	A field for entering the instrument's serial number
Manufacturer	A field for entering the instrument's manufacturer
Model	A field for entering the instrument model
Sensor Serial Number	A field for entering the sensor's serial number, if applicable

Input Data Page

Data related to the instrument's input.

Note that this list presents all input data page fields. The ones visible for you depends on the selected **Function** (first field in the list below):

FIELD	DESCRIPTION
Function	The function needed in MC4 to determine the instrument's input.
Display Resolution	Select a suitable display resolution from the available list. This field is visible when the selected Function is: Manually Keyed Value
Unit	This field is visible for all Functions
Sensor	Select an applicable sensor from the available list. This field is visible when the selected Function is: T/C Sensor Measurement, T/C Sensor Simulation, RTD Sensor Measurement or RTD Sensor Simulation.
RJ Mode	Select an applicable Reference Junction Mode from the available list. More info of Reference Junction Modes in part C, chapter Internal Reference Junction on page 113 and External Reference Junction on page 114 . This field is visible when the selected Function is: T/C Sensor Measurement or T/C Sensor Simulation.
HART Compatible Loop Supply	Check if the current supplied by MC4 needs to be HART Compatible. This field is visible when the selected Function is: Current Meas., Supply On.

Continues on next page...

FIELD <i>(cont.)</i>	DESCRIPTION
<p>Switch Sound</p>	<p>Defines when MC4 emits a sound when the switch changes its state. Options:</p> <ul style="list-style-type: none"> No Sound Sound Open Sound Closed When Changed <p>This field is visible when the selected Function is:</p> <ul style="list-style-type: none"> Switch.
<p>Trigger Edge</p>	<p>Select whether it is the Rising or the Falling edge that Pulse Counting uses.</p> <p>This field is visible when the selected Function is:</p> <ul style="list-style-type: none"> Pulse Counting.
<p>Trigger Level</p>	<p>Specify the trigger level and whether to use a test voltage during the measurement.</p> <p>This field is visible when the selected Function is:</p> <ul style="list-style-type: none"> Frequency Measurement, Pulse Counting or Switch.
<p>Waveform</p>	<p>Select Waveform and specify Duty Cycle percentage (the ratio of the output high time to the total cycle time).</p> <p>This field is visible when the selected Function is:</p> <ul style="list-style-type: none"> Frequency Generation, or Pulse Generation.
<p>Amplitude</p>	<p>Define the amplitude of the generated wave/pulse.</p> <p>This field is visible when the selected Function is:</p> <ul style="list-style-type: none"> Frequency Generation, or Pulse Generation.
<p>External Supply, Sink Current (reverse polarity)</p>	<p>Check if you use an external supply when generating current. When checked MC4 acts as a current sink controlling the current.</p> <p>This field is visible when the selected Function is:</p> <ul style="list-style-type: none"> Current Source or Sink.

Output Data Page

Data related to the instrument's output.

Note that this list presents all output data page fields. The ones visible for you depends on the selected **Function** (first field in the list below):

FIELD	DESCRIPTION
Function	The Function needed in MC4 to determine the instrument's output.
Display Resolution	Select a suitable display resolution from the available list. This field is visible when the selected Function is: Manually Keyed Value
Unit	This field is visible for all Functions
Sensor	Select an applicable sensor from the available list. This field is visible when the selected Function is: T/C Sensor Measurement or RTD Sensor Measurement
RJ Mode	Select an applicable Reference Junction Mode from the available list. More info of Reference Junction Modes in part C, chapter Internal Reference Junction on page 113 and External Reference Junction on page 114 . This field is visible when the selected Function is: T/C Sensor Measurement.
HART Compatible Loop Supply	Check if the current supplied by MC4 needs to be HART Compatible. This field is visible when the selected Function is: Current Meas., Supply On.

Continues on next page...

FIELD <i>(cont.)</i>	DESCRIPTION
<p>Switch Sound</p>	<p>Defines when MC4 emits a sound when the switch changes its state. Options:</p> <p>No Sound Sound Open Sound Closed When Changed</p> <p>This field is visible when the selected Function is:</p> <p>Switch.</p>
<p>Trigger Edge</p>	<p>Select whether it is the Rising or the Falling edge that Pulse Counting uses.</p> <p>This field is visible when the selected Function is:</p> <p>Pulse Counting.</p>
<p>Trigger Level</p>	<p>Specify the trigger level and whether to use a test voltage during the measurement.</p> <p>This field is visible when the selected Function is:</p> <p>Frequency Measurement, Pulse Counting or Switch.</p>
<p>Invert Switch Open/Closed States</p>	<p>Check if you want to display the switch's state inverted in MC4.</p> <p>This field is visible when the selected Function is:</p> <p>Switch.</p>

Function Data Page

Data related to the instrument's functionality.

FIELD	DESCRIPTION
<p>Input Range, 0 % 100 %</p>	<p>Enter the input range's minimum and maximum value here.</p>
<p>Transfer Function</p>	<p>Defines the instrument's input/output correlation.</p> <p>Available options (with no custom Transfer Functions):</p> <ul style="list-style-type: none"> Linear \sqrt{x} $\sqrt{x^3}$ $\sqrt{x^5}$ $\sqrt{x^2}$ Create New... <p>The last item in the list allows you to make your own custom transfer function. Custom transfer functions are presented in chapter Custom Transfer Functions on page 103.</p> <p>This field is visible for all other instruments, except Switches.</p>
<p>Output Range, 0 % 100 %</p>	<p>Enter the output range's minimum and maximum value here.</p> <p>This field is visible for all other instruments, except Switches.</p>
<p>Set Action</p>	<p>Here you define what a switch does when it sets (actuates). Available options:</p> <ul style="list-style-type: none"> Opens Closes <p>This field is visible when the selected Function is:</p> <ul style="list-style-type: none"> Switch.
<p>Nominal Set & Reset</p>	<p>Enter the switch's nominal set and reset (actuating and deactuating) point values here.</p> <p>This field is visible when the selected Function is:</p> <ul style="list-style-type: none"> Switch. <p style="text-align: right;"><i>Continues on next page...</i></p>

FIELD <i>(cont.)</i>	DESCRIPTION
Function Name	Here you may enter a descriptive name for the Function. The field expands when the name is longer than a single row.
Channel Name	This field and the next one are usable, when the instrument at hand has several similar functions. Here you may enter a descriptive name for the current channel.
Channel Number	<p>Here you may enter the number of the current channel. This field, just as the previous one are usable, when the instrument at hand has several similar functions.</p> <p>Warning! If you have received multi-channel instruments from a calibration software, do not edit the channel number in MC4.</p>

Procedure Data Page

MC4 Data related to the calibration procedure.

Since the fields for switches and non-switches (i.e. regular instruments) vary significantly, they are presented in separate tables.

Procedure fields for non-switches

(Procedure fields for switches are presented further on)

FIELD	DESCRIPTION
<p>Calibration Points</p>	<p>Defines how the stepping is done Available options (with no custom sets):</p> <p>3: 50 % 5: 25 % 6: 20% 11: 10 % 0%>10>25>50>75>90>100 0%>2>4>50>96>98>100 0%>5>40>100 -2%>0>2>4>50>96>98>100>102 Create New...</p> <p>The group of sets starting with a number and colon are sets with fixed step sizes. The first number is the amount of step levels and the percentage value is the step size.</p> <p>The group of sets starting with a number and percentage symbol are sets with varying step sizes (suitable for, e.g. valve tests). Each number is a step level.</p> <p>The last item in the list allows you to make your own custom step definition. Custom steps are presented in chapter Custom Test Point Sets on page 101.</p>
<p>Repeat Format</p>	<p>This setting specifies how the calibration points are used during calibration. Available options:</p> <p>Up / Down Down / Up Up Down</p> <p style="text-align: right;"><i>Continues on next page...</i></p>

FIELD <i>(cont.)</i>	DESCRIPTION
<p>Automatic Calibration Point Acceptance</p>	<p>Check if you want MC4 to automatically accept calibration points. See also additional settings further on in this table and chapter Accepting Calibration Points Automatically on page 178.</p>
<p>Setpoint Delay</p>	<p>All instruments have a response time for a change in the output after the input was changed. The response time varies depending on the instrument type and its filtering settings etc.</p> <p>In automatic calibration, MC4 needs to wait until the response time has passed. Otherwise the instrument's output is read too soon.</p> <p>Enter a setpoint delay that suits the instrument. If you are not sure what the response time is, test the instrument in basic mode. Change the input signal to get an approximation of the response time.</p> <p>This field is active only if previous Check box is set.</p>
<p>Max Point Deviation</p>	<p>Defines the input signal's allowed deviation (+/-) from the current calibration point (percent of input span). When inside this "target area", the calibration point is automatically accepted (if applicable).</p> <p>The target area is shown as a grey vertical bar in the Graphics View. Note that zero deviation means you do not see the target area while calibrating in Graphics View</p> <p>See also the next field in this table and chapter Accepting Calibration Points Automatically on page 178.</p>
<p>Require also Stable Output Measurement</p>	<p>When checked, MC4 monitors the stability of the output signal when accepting calibration points.</p> <p>See also previously presented fields:</p> <ul style="list-style-type: none"> - Automatic Calibration Point Acceptance - Max Point Deviation <p>and chapter Accepting Calibration Points Automatically on page 178.</p> <p style="text-align: right;"><i>Continues on next page...</i></p>

FIELD <i>(cont.)</i>	DESCRIPTION
Supervised Advancement to Next Calibration Point	If checked, advancing to next calibration point requires user intervention.
Limited Checking Range for Pass/Fail Detection	<p>If checked, you may enter a pass/fail detection range that differs from the instrument's input/output range. See also next field.</p> <p>Note that this setting is currently not supported by calibration software. Thus the pass/fail result may differ between MC4 and the calibration software.</p>
Checking Range, 0 % 100 %	<p>Active only if previous Check box is set. Enter the checking range for limited pass/fail detection.</p> <p>Note that the checking range is currently not supported by calibration software.</p>

Procedure fields for switches

FIELD	DESCRIPTION
Automatic Calibration Point Acceptance	Check if you want MC4 to automatically accept calibration points. See also chapter Accepting Calibration Points Automatically on page 178.
Switch Ramp/Scan Ranges, Set Point 0 %, 100 %	<p>Switch's set point should be within this range. For best results, enter a range that is symmetric in regard to the set point.</p> <p style="text-align: right;"><i>Continues on next page...</i></p>

FIELD <i>(cont.)</i>	DESCRIPTION
<p>... Reset Point 0 % , 100 %</p>	<p>Switch's reset point should be within this range. For best results, enter a range that is symmetric in regard to the set point.</p> <p>Note.</p> <p>MC4 starts scanning for the reset point after the set point is found. The scan starts from 0% value towards the 100 % value. Make sure you define the range so that the scan advances toward the reset point and does not immediately jump passed it.</p>
<p>Use Prescan</p>	<p>If enabled, at the beginning of switch calibration, MC4 searches for approximate values for the set and reset point. This speeds up the final test without sacrificing accuracy. The prescan test is done only once in a calibration.</p> <p>Note that prescan is of use only when MC4 is generating/simulating the switch's output.</p>
<p>Update Switch Scan Range Automatically</p>	<p>Active only if previous check box is set. If this one is checked, the Switch Ramp/Scan Ranges are used during prescan. During the actual scan for set and reset point, a smaller range based on prescan data is used. This produces more accurate results.</p> <p>Note that the prescan and scan range update is needed when it is taken into use only (applies for a stable switch).</p>
<p>Step Response Wait [ms]</p>	<p>This field is comparable to Setpoint Delay field for non-switches. It defines the time (in milliseconds) MC4 waits for the switch's output to react after a step change in the input was done. This setting is used during prescan.</p> <p>If you get an error message during prescan, check the scan ranges and try increasing this value. Some switches may require a wait time of a few seconds (few thousands of milliseconds).</p> <p style="text-align: right;"><i>Continues on next page...</i></p>

FIELD <i>(cont.)</i>	DESCRIPTION
Final Ramp Delay [ms]	<p>This setting defines the ramp's change rate during the final search for set and reset point.</p> <p>Try, e.g. using a 30 millisecond delay . If the detected set and reset points seem too inconsistent, increase this value and try again. Keep in mind, however, that a defective switch is always inconsistent, no matter how you increase the delay.</p>
Switch Test Cycles	<p>How many test cycles (set/reset) is done for each As Found or As Left calibration run.</p>

Error Limits Data Page

Data related to the error calculation and error limits.

FIELD	DESCRIPTION
Error Calculation Method	Select one of the error calculation methods Available options: <ul style="list-style-type: none"> % of output span Absolute (input unit) Absolute (output unit) More in depth presentations of the options are available in chapter Error Calculation Formulas on page 181.
Reject if >	Calibration fails if found error exceeds this value at some point.
Adjust if >	If value is other than zero, MC4 suggests that you do adjust the instrument if found error exceeds this value at some point.
Do not adjust if <	If value is other than zero, MC4 suggests that you do not adjust the instrument if found error exceeds this value at some point.
Adjust to <	If value is other than zero, MC4 suggests that you adjust the instrument's found maximum error below this limit.
Display Resolution	Active only if is Error Calculation Method set to "% of span". Then you may select one of the available resolutions for presenting the calculated error.
Error Calculation Domains Set Point Reset Point	Defines which types of error are taken into account with switches. Both Set and Reset point have their own independent settings. Available options: <ul style="list-style-type: none"> +/-, <i>All errors are reported/valid</i> +, <i>Only positive errors are valid</i> -, <i>Only negative errors are valid</i> None <i>No errors are reported</i> This field is visible for switches only <p style="text-align: right;"><i>Continues on next page...</i></p>

FIELD <i>(cont.)</i>	DESCRIPTION
<p>Use Separate Switch Reset Point Error Limits</p>	<p>Sometimes the set point of a switch is more important than the reset point (or vice versa). Then you may want to set a separate reject error limit for the reset point. To do this, set this check box.</p> <p>This field is visible for switches only</p>
<p>Reject if ></p>	<p>Active only if previous Check box is set.</p> <p>Enter a reject error limit for the reset point.</p>

General Data Page

This is additional data typically received from a calibration software. You also may enter/edit the data in MC4.

FIELD	DESCRIPTION
Work Order	The work order number/code for the calibration of the current instrument.
Calibration Interval	The time interval between calibrations.
Number of Calibration Repeats, - As Found Results - As Left Results	<p>Defines how many As Found and As Left repeats should be done.</p> <p>If a value other than zero is entered, after a calibration is saved a window opens telling you how many repeats are done and how many should be done.</p> <p>If the values are zeros, the above mentioned functionality is disabled.</p>
Before Calibration Note	<p>Instructions helping you to prepare calibration. Free text field that expands with the amount of text.</p> <p>If this field contains text, it is shown after the F3/Start button is pressed for the first time.</p> <p>See also chapter Guidance Texts on page 180.</p>
Adjustment Note	<p>Instructions helping you to adjust the instrument. Free text field that expands with the amount of text.</p> <p>If this field contains text, it is shown when the adjustment window is opened (F1/Menu, Adjust Instrument).</p>
After Calibration Note	<p>Instructions helping you to finish the calibration. Free text field that expands with the amount of text.</p> <p>If this field contains text, it is shown when you close the calibration window.</p>

Saving an Edited Instrument

When you are ready with editing the instrument press the **F3/Close** Function Key available on all instrument data pages. A menu like the opens shown in the rightmost picture below. Saving

The image shows two side-by-side screenshots of the 'POSITION 1/8' data entry screen. The left screenshot shows the form with fields for Position ID (TTAPMTSUWA111.1), Position Name (WA Temperature Transmitter), and Position Location (Level 19, area V67). At the bottom are buttons for 'View', 'More', and 'Close'. A green arrow points from the 'Close' button to the right screenshot. The right screenshot shows the same form, but the 'Close' button has been pressed, opening a menu with three options: 'Save', 'Save a Copy', and 'Cancel Changes'. At the bottom of this screen are buttons for 'Cancel', 'Bottom', and 'Select'.

Scroll through the menu using the up ▲ and down ▼ arrow keys and select an option with the Enter Key (↵).

Note.

When you choose **Save a Copy**, the original instrument (source) is left unchanged and a new instrument is created based on the edited instrument data. Possible calibration result data is not copied, but stays linked to the original instrument.

Viewing Calibration Results

Calibration Result Windows

You can open the calibration result windows from two places:

- When viewing the instrument list, press **F3/Menu, Result History**.
- When the calibration window is open, press **F1/Menu, Result History**.

Note that the **Result History** menu option is available only if there are saved calibrations for the selected instrument.

The result window always opens displaying the latest results in numeric format. The error presented in the third column is based on the selected error calculation method.

For more information of error limits and error calculation, see chapter **Error Limits Data Page** on page 170 and chapter **Error Calculation Formulas** on page 181.

PASSED		
Input	Output	Error
0.00	4.0767	0.48
25.00	8.0703	0.44
50.00	12.056	0.35
75.00	16.0463	0.29
100.00	20.0416	0.26
75.00	16.0464	0.29
50.00	12.057	0.35
25.00	8.0704	0.44
0.00	4.0768	0.48
Menu	More	Close

Use up and down arrow keys (▲ and ▼) to highlight a row in the result grid (and see more results if there are more results that can be seen on the display). Press Enter key (↵) to see more data of highlighted row. See also chapter **Extra Information Saved With Calibration Point Data** on page 177.

To see other result pages, select **F2/More**.

The second calibration result page presents the calibration info page in read only mode.

This data was available for editing after the calibration run was done and before the results were saved.

CALIBRATION INFO

Calibration Remark

Calibrated By

Work Time [minutes]

Environment Information
 Humidity [%]

The third calibration result page displays the error graph together with found maximum error. The dotted lines are the reject error limits, positive and negative.

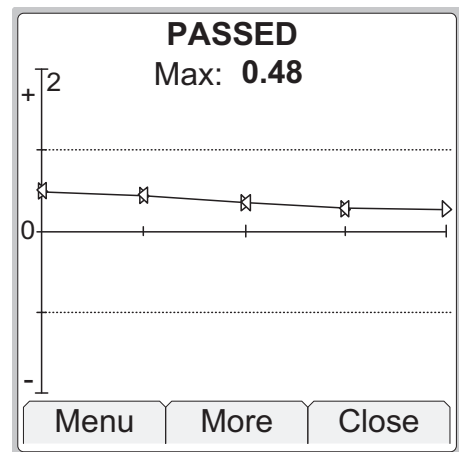

How to Choose Which Calibration Run is Viewed

To view another calibration result, press **F1/Menu**.

The picture on the right displays the full calibration result menu.

Options **Show Older Result** and **Show Newer Result** are visible only if there are older (correspondingly newer) results available and the results have the same instrument data.

PASSED

Input	Output	Error
0.00	4.0767	0.48
25.00	8.0703	0.44
50.00	12.056	0.35
		0.29
		0.26
		0.29
		0.35
		0.44
		0.48

Show Older Result

Show Newer Result

Result History ...

Delete this Result

Delete All Results

To see a list of all results, select **Result History**.

The list of results has the latest calibration results on top of the list.

Passed calibrations have a "✓" symbol preceding the date and time.

Failed calibrations are prefixed with a "✗" symbol.

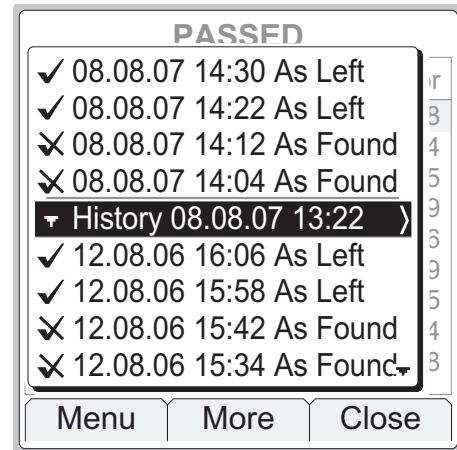

Whenever the instrument data has been edited, the calibration result list has a separate row entitled **History** indicating that the instrument data was changed at that point. See highlighted row in the picture above.

Each **History** row are prefixed with a triangle pointing down and has a line above. The date and time shown on the **History** row is the moment the instrument data change was saved. A chevron pointing right "▸" indicates that by selecting this row you may view the instrument data **preceding** the change, i.e. related to the calibrations listed below the **History** row.

Note that the instrument data shown is read-only.

Deleting Calibration Results

Calibration results may deleted while viewing the calibration result window:

- To delete the **currently viewed results**, press **F1/Menu, Delete this Result**. Note that this possibility is not available in the instrument list window menu.
- To delete **all results for all instruments**, press **F1/Menu, Delete All Results**.

Note.

There are tools for deleting calibration results in the instrument list window menu too. There you may also delete **all results for the currently selected instrument** leaving the results of other instruments intact. More of the instrument list window menu in chapter **Instrument List Window Menu** on page 152.

Additional Calibration Related Information

This chapter and its subchapters complement information presented in other section D chapters.

Extra Information Saved With Calibration Point Data



Along with the input and output values, MC4 saves the following data for each calibration point (when applicable). Some data is stored automatically and some may be manually entered.

Data automatically stored by MC4:

- MC4 modules used in current calibration point and
- Resolution for manually entered value.

Data that can be manually entered on point level:

- Used Reference Module for manually entered value,
- Separate Barometric Module used in conjunction with high pressure gauge modules,
- Reference Sensor for manually entered value, and measured values and
- Sensor used for measuring the temperature of the Reference Junction for manually entered value, and when an external sensor is used for measuring the Reference Junction.

Note that this data may be edited in the calibration window's menu (F1/Menu, **Instrument Input**  and F1/Menu, **Instrument Output** ). Which ones are available depends on the selected Input/Output Function.

Furthermore, when applicable, corresponding data is shown among calibration results.

Accepting Calibration Points Automatically

The following rules apply when MC4 automatically accepts calibration points:

- The input must be inside the **Max Point Deviation** target area before the automatic calibration point acceptance procedure initiates.
- If **Require also Stable Output Measurement** check box is set, the following procedure applies:
 1. As long as the **input and/or output** is unstable (symbol  visible in Numeric Mode), calibration points are not automatically accepted.
 2. When both **input and output** are stable, MC4 waits for a time period defined in **Setpoint Delay** field.
 3. During the wait time:
If either **input or output** is unstable, the wait time is interrupted and MC4 restarts the procedure from the beginning.
 4. In case both **input and output** were stable all through the wait time, the results are automatically saved.
- Otherwise, the following procedure applies:
 1. As long as the **input** is unstable, calibration points are not automatically accepted.
 2. When **input** is stable, MC4 waits for a time period defined in **Setpoint Delay** field.
 3. During the wait time:
If **input** is unstable, the wait time is interrupted and MC4 restarts the procedure from the beginning.
 4. In case **input** was stable all through the wait time:
If **output** is stable, the results are automatically saved.
If **output** is unstable, MC4 waits for an additional five seconds allowing the output to settle. Then the results are saved no matter how unstable the output may be.

If you accept a calibration point using **F3/Accept** Function Key, the following rules apply (no matter if you are using **Automatic Calibration Point Acceptance** or not):

- If the input is unstable, a window opens asking you to confirm the accepting of the calibration point although the input is unstable.
- If **Require also Stable Output Measurement** is set and the output is unstable, MC4 asks you to confirm the accepting of the calibration point.
- Otherwise, MC4 accepts the calibration point.



Changing the Pressure Module During Calibration

The calibration of a pressure instrument may be done using only one pressure module (internal or external). If you have several pressure modules available, you may however use a smaller range pressure module (with greater accuracy) for the instrument's lower range. Then when the pressure is too high for the pressure module with smaller range switch to a pressure module capable of measuring higher pressures.

To change pressure module during calibration do as follows:

Select

F1/Menu,

Instrument Input  or **Instrument Output** ,

F2/Tools,

Change Pressure Module.

A menu with the following options opens:



MENU ITEM	DESCRIPTION
Int. Pressure (NMPxxx)	The Internal Pressure Module is selected.
Ext. Pressure (EXTxxx)	The currently connected External Pressure Module is selected.
Change to Another EXT	<p>Allows you to remove the currently connected External Pressure Module and replace it with another.</p> <p>To change the External Pressure Module, do as follows:</p> <ol style="list-style-type: none"> 1. Select this menu option, 2. Remove the currently connected External Pressure Module. 3. Wait until MC4 emits a "bleep" informing that the removal of the External Pressure Module is noticed. 4. Connect another External Pressure Module. <p>When the new External Pressure Module is connected and communicates with MC4, a window is opened displaying info of the connected External Pressure Module. Select F3/Ok to continue calibration</p> <p>Not following these instructions may result in an interrupted calibration.</p>

Zeroing a Pressure Module During Calibration

If the pressure module in use does not display zero gauge pressure when the applied pressure is zero, the module has to be zeroed. The following instructions to zero a pressure module applies both before the calibration is started and during calibration:

Select

F1/Menu,

Instrument Input  or **Instrument Output** ,

F1/Zero Pressure.

The zeroing will be applied to the pressure module currently in use.

Guidance Texts

MC4 allows you to enter three guidance texts for instruments:

Before Calibration Note, Adjustment Note and **After Calibration Note**. These are shown at appropriate stages during a calibration run. The notes may also be received from a calibration software. More of these guidance texts in chapter **General Data Page** on page 172.

If you use a calibration software to add calibration point level notes, they may be also sent to MC4. These are also shown at appropriate stages during a calibration run. However, point level notes cannot be edited in MC4.

Environmental Data

Depending on **Functions** used in calibration, some of the environmental data on **Calibration Info** page is pre-entered. Also note that the fields on **Calibration Info** page are editable before the calibration is saved. After the results are saved, the data on **Calibration Info** page can be seen in calibration result pages, but they are no longer editable.

Error Calculation Formulas

Percent of Output Span:
$$E_{O \text{ span}} = \frac{O - O_{\text{ideal}}}{O_{\text{fs}} - O_{\text{zero}}} \cdot 100 \%$$

Where

- $E_{O \text{ span}}$ is the calculated output error (percent of span) for a calibration point.
- O is the measured output for a calibration point.
- O_{ideal} is the theoretical output value at a calibration point.
- O_{fs} is the theoretical output value at Output 100% (full scale).
- O_{zero} is the theoretical output value at Output 0%.

Absolute (output unit):
$$E_{O \text{ abs}} = O - O_{\text{ideal}}$$

Where

- $E_{O \text{ abs}}$ is the calculated absolute output error for a calibration point.

Other terms are similar to Percent of Output Span equation.

Absolute (input unit):
$$E_{I \text{ abs}} = I_{\text{ideal}} - I$$

Where

- $E_{I \text{ abs}}$ is the calculated absolute input error for a calibration point.
- I_{ideal} is the measured output value projected (using the transfer function equation) to input, i.e. the input value that theoretically produces the measured output value.
- I is the measured input for a calibration point.

Combining Calibration Repeats

There is a check box entitled **Combine with Previous Calibration Results** on the **Calibration Info** page. If checked, the latest calibration will be combined with the previous result as one calibration event when it is saved. All combined results are received in calibration software (such as CMX) as one calibration event containing several repeats. The check box is automatically set if there is less than three days between the current and previous calibration.

If you have defined **Number Of Calibration Repeats** for the instrument, then MC4 opens a window after you have saved calibration results. The window informs you of how many repeats are done and how many repeats are supposed to be done. More of this feature in chapter **General Data Page** on page 172.

Results and Memory Usage

If you are calibrating instruments using off-line method then please keep in mind this: When you upload the results from MC4 to the calibration software, the results are by default also left in MC4's memory. Delete results to free memory in MC4 as described in chapter **Instrument List Window Menu** on page 152.

Appendixes

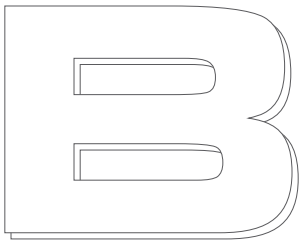
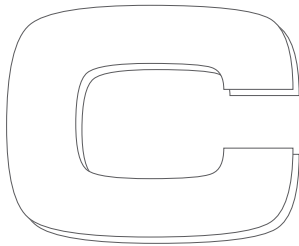
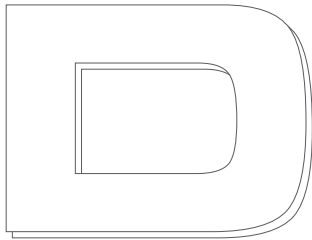

Appendix 1
Technical Data 184
Appendix 3
Index 203

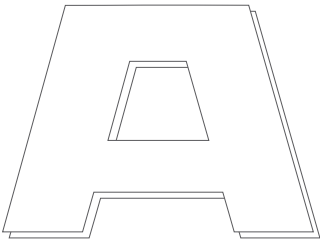

Appendix 1, Technical Data

MC4 General Specifications

Feature	Specification
Display	60 mm x 60 mm (2.36" x 2.36"), 160 x 160 pixels, back lit LCD
Weight	820 g (1.8 lbs)
Dimensions	215 mm (8.5") x 102 mm (4") x 49 mm (1.9") (d/w/h)
Keyboard	Membrane keyboard
Battery type	Rechargeable NiMH, 4000 mAh, 3.6V DC
Charging time	5 hours, with no load
Charger supply	100...240 VAC, 50-60 Hz
Battery operation	13 hours in measurement mode, backlight off. 8 hours when sourcing an average of 12 mA to loop, with backlight on.
... with optional Dry Battery cartridge and 4 Alkaline AA cells.	4 hours in measurement mode, backlight off. 2.5 hours when sourcing an average of 12 mA to loop, with backlight on.
Operating temperature	-10...50°C (14...122°F)
Operating temperature while charging batteries	0 ... 35°C (32...95°F)
Storage temperature	-20 to 60°C (-4 to 140°F)
Humidity	0 to 80% R.H. non condensing
Warmup time	Specifications valid after a 5 minute warmup period.
Max. input voltage	30 V AC, 60 V DC
Safety	Directive 73/23/EEC, EN 61010-1
EMC	Directive 89/336/EEC, EN 61326

Electrical Measurements

Available in Measure section.

Voltage Measurement

Full Range: -1 ... 60 V DC		
Sub Range	Resolution	1 Year Uncertainty ¹⁾
± 0.25 V	0.001mV	0.02 % RDG + 5 µV
±(0.25 ... 1 V)	0.01 mV	(same as above)
1 ... 25 V	0.1 mV	0.02 % RDG + 0.25 mV
25 ... 60 V	1 mV	(same as above)

Feature	Specification
Temperature coefficient	Add 0.0015 % RDG /°C to spec. outside 18 ... 28°C Add 0.0008 % RDG /°F to spec. outside 64.4 ... 82.4°F
Input impedance	>1 Mohm
Supported units	V, mV, µV
Display update rate	3 / second

Current Measurement

Full Range: ±100 mA		
Sub Range	Resolution	1 Year Uncertainty ¹⁾
±25mA	0.0001 mA	0.02 % RDG + 1.5 µA
±(25..100 mA)	0.001 mA	(same as above)

Feature	Specification
Temperature coefficient	Add 0.0015 % RDG /°C to spec. outside 18 ... 28°C Add 0.0008 % RDG /°F to spec. outside 64.4 ... 82.4°F
Input impedance	< 7.5 ohm
Supported units	mA, µA
Display update rate	3 / second

Loop Supply	Specification
Max. output current	> 25 mA, short circuit protected
Output voltage	24 V ± 10%
Output impedance in HART compatible mode	300 ohm ± 20%

¹⁾ Uncertainty includes reference standard uncertainty, hysteresis, nonlinearity, repeatability and typical long term stability for mentioned period. (k=2)

Frequency Measurement

Full Range: 0.0027 ... 50 000 Hz		
Sub Range	Resolution	1 Year Uncertainty ¹⁾
0.0027 .. 0.5 Hz	0.000001 Hz	0.01 % RDG
0.5 .. 5 Hz	0.00001 Hz	(same as above)
5 .. 50 Hz	0.0001 Hz	(same as above)
50 .. 500 Hz	0.001 Hz	(same as above)
500 .. 5000 Hz	0.01 Hz	(same as above)
5000 .. 50000 Hz	0.1 Hz	(same as above)

Feature	Specification
Temperature coefficient	Specification valid from -10 ... 50°C (14 ... 122°F)
Input impedance	> 1 Mohm
Trigger level	-1... 14 V in 1 V steps and open collector inputs
Minimum signal amplitude	2 Vpp (< 10 kHz), 3 Vpp (10...50 kHz)
Supported units	Hz, kHz, cph, cpm, 1/Hz (s), 1/kHz (ms), 1/MHz (µs)
Gate period	267 ms + 1 signal period

Pulse Counting

Feature	Specification
Range	0 to 9,999,999 pulses
Input impedance	> 1 Mohm
Trigger level	-1... 14 V in 1 V steps and open collector inputs
Minimum signal amplitude	2 Vpp (pulse length > 50 µs) 3 Vpp (pulse length 10...50 µs)

Switch Test

Potential free contacts	
Test Voltage (Trigger level)	3 V 0.13 mA (1 V) or 24 V 35 mA (2 V)

Voltage level detection	
Input impedance	> 1 Mohm
Trigger level	-1... 14 V in 1 V steps

¹⁾ Uncertainty includes reference standard uncertainty, hysteresis, nonlinearity, repeatability and typical long term stability for mentioned period. (k=2)

Electrical Generation, Sensor Measurement and Simulation

Available in Temperature/Generate section.

mV Measurement (T/C-Terminals)

Range	Resolution	1 Year Uncertainty ¹⁾
-25 ... 150 mV	0.001mV	0.02 % RDG + 4 μ V

Feature	Specification
Temperature coefficient	Add 0.0015 % RDG /°C to spec. outside 18 ... 28°C Add 0.0008 % RDG /°F to spec. outside 64.4 ... 82.4°F
Input impedance	>10 Mohm
Supported units	V, mV, μ V
Display update rate	3 / second

mV Generation (T/C-Terminals)

Range	Resolution	1 Year Uncertainty ¹⁾
-25 ... 150 mV	0.001 mV	0.02 % RDG + 4 μ V

Feature	Specification
Temperature coefficient	Add 0.0015 % RDG /°C to spec. outside 18 ... 28°C Add 0.0008 % RDG /°F to spec. outside 64.4 ... 82.4°F
Max. load current	5 mA
Load effect	< 5 μ V/mA
Supported units	V, mV, μ V

¹⁾ Uncertainty includes reference standard uncertainty, hysteresis, nonlinearity, repeatability and typical long term stability for mentioned period. (k=2)

Voltage Generation

Full Range: -3 ... 12 V		
Sub Range	Resolution	1 Year Uncertainty ¹
-3 ... -0.25 V	0.1 mV	0.01 % RDG
± 0.25 V	0.01 mV	(same as above)
0.25 ... 12 V	0.1 mV	(same as above)

Feature	Specification
Temperature coefficient	Add 0.0015 % RDG /°C to spec. outside 18 ... 28°C Add 0.0008 % RDG /°F to spec. outside 64.4 ... 82.4°F
Max. load current	5 mA
Load effect	< 50 uV/mA
Supported units	V, mV, µV

mA Generation (Source/Sink)

Range	Resolution	1 Year Uncertainty ¹
0... 25 mA	0.0001mA	0.02 % RDG + 4 µV

Feature	Specification
Temperature coefficient	Add 0.0015 % RDG /°C to spec. outside 18 ... 28°C Add 0.0008 % RDG /°F to spec. outside 64.4 ... 82.4°F
Max load impedance (source)	750 ohm @20 mA, 600 ohm @25 mA
Max loop voltage (sink)	60 V
Supported units	mA, µA

¹) Uncertainty includes reference standard uncertainty, hysteresis, nonlinearity, repeatability and typical long term stability for mentioned period. (k=2)

Resistance Measurement

Full Range: 0 ... 4000 ohm		
Sub Range	Resolution	1 Year Uncertainty ⁽¹⁾
0 ... 250 ohm	1 mohm	4 wire connection: 0.02 % RDG + 3.5 mohm 3 wire connection: 0.02 % RDG + 13.5 mohm
250 ... 2650 ohm	10 mohm	(same as above)
2650 ... 4000 ohm	100 mohm	(same as above)

Feature	Specification
Temperature coefficient	Add 0.0015 % RDG /°C to spec. outside 18 ... 28°C Add 0.0008 % RDG /°F to spec. outside 64.4 ... 82.4°F
Measurement current	Pulsed, bi-directional 1 mA (0 ... 500 ohm), 0.2 mA (>500 ohm).
Supported units	ohm, kohm
Display update rate	3 / second

Resistance Simulation

Full Range: 0 ... 4000 ohm		
Sub Range	Resolution	1 Year Uncertainty ^{(1) (2)}
0 ... 400 ohm	10 mohm	0.04 % RDG or 30 mohm (Whichever is greater)
400 ... 4000 ohm	100 mohm	(same as above)

Feature	Specification
Temperature coefficient	Add 0.0015 % RDG /°C to spec. outside 18 ... 28°C Add 0.0008 % RDG /°F to spec. outside 64.4 ... 82.4°F
Max. Resistance excitation current	5 mA (0 ... 650 ohm) $I_{exc} \cdot R_{sim} < 3.25 \text{ V}$ (650 ... 4000 ohm)
Settling time (pulsed currents)	1 ms
Supported units	ohm, kohm

¹⁾ Uncertainty includes reference standard uncertainty, hysteresis, nonlinearity, repeatability and typical long term stability for mentioned period. (k=2)

²⁾ Specification valid with an excitation current
>0.2 mA (0...400 ohm),
>0.1 mA (400...4000 ohm)

Frequency Generation

Full Range: 0.0005 ... 10000 Hz		
Sub Range	Resolution	1 Year Uncertainty ¹⁾
0.0005 ... 0.5 Hz	0.000001 Hz	0.01 % RDG
0.5 ... 5 Hz	0.00001 Hz	(same as above)
5 ... 50 Hz	0.0001 Hz	(same as above)
50 ... 500 Hz	0.001 Hz	(same as above)
500 ... 5000 Hz	0.01 Hz	(same as above)
5000 ... 10000 Hz	0.1 Hz	(same as above)

Feature	Specification
Temperature coefficient	Specification valid from -10 to 50°C (14...122°F)
Max. load current	5 mA
Output amplitude positive square wave	0 .. 12 Vpp ±(0.2 V+5%)
Output amplitude symmetric square wave	0 .. 6 Vpp ±(0.2 V+5%)
Duty Cycle	1 ... 99 % (0.0009 ... 500 Hz), high/low time: minimum 25µs, maximum 1165 s
Jitter	< 0.28 µs
Supported units	Hz, kHz, cph, cpm, 1/Hz (s), 1/kHz (ms), 1/MHz (µs)

Pulse Generation

Feature	Specification
Range	0 to 9 999 999 pulses
Resolution	1 pulse
Max. load current	5 mA
Output amplitude positive pulse	0 .. 12 Vpp ±(0.2 V+5%)
Output amplitude symmetric pulse	0 .. 6 Vpp ±(0.2 V+5%)
Pulse frequency	0.0005 ... 10000 Hz
Duty Cycle	1 ... 99 % (0.0009 ... 500 Hz), high/low time: minimum 25µs, maximum 1165 s

¹⁾ Uncertainty includes reference standard uncertainty, hysteresis, nonlinearity, repeatability and typical long term stability for mentioned period. (k=2)

Temperature Measurement and Simulation

Available in Temperature/Generate section.

RTD Measurement and Simulation

Common features for RTDs available as standard:

Feature	Specification
Temperature coefficient	< $\pm 0.0015\%$ of resistance / °C outside of 18...28°C < $\pm 0.0008\%$ of resistance / °F outside of 64.4 ...82.4°F
Supported units	°C, °F, K
Measurement current	Pulsed, 1 mA (0..500 ohm), 0.2 mA (>500 ohm).
Display update rate (measurement)	3 / second
Max. Resistance excitation current (simulation)	5 mA (0 ... 650 ohm) $I_{exc} \cdot R_{sim} < 3.25 \text{ V}$ (650 ... 4000 ohm)

Pt50 ... Pt1000

Full Range: -200 ... 850 °C		
Sub Range	Resolution	1 Year Uncertainty ⁽¹⁾
-200 ... 0 °C	0.01 °C	4-wire measurement: 0.06 °C Simulation ⁽²⁾ : 0.1 °C
0 ... 850 °C	0.01 °C	4-wire measurement: 0.06 °C + 0.025 % RDG Simulation ⁽²⁾ : 0.10 °C + 0.025 % RDG

Ni 100

Range	Resolution	1 Year Uncertainty ⁽¹⁾
-60 ... 180 °	0.01 °C	4-wire measurement: 0.06 °C Simulation ⁽²⁾ : 0.12 °C

¹⁾ Uncertainty includes reference standard uncertainty, hysteresis, nonlinearity, repeatability and typical long term stability for mentioned period. (k=2)

²⁾ Specification valid with an excitation current
>0.2 mA (0...400 ohm),
>0.1 mA (400...4000 ohm)

Ni 120

Range	Resolution	1 Year Uncertainty ¹
-80 ... 260 °C	0.01 °C	4-wire measurement: 0.06 °C Simulation ² : 0.12 °C

Cu 10

Range	Resolution	1 Year Uncertainty ¹
-200 ... 260 °C	0.01 °C	4-wire measurement: 0.2 °C Simulation ² : 0.8 °C

RTD Types Available as Standard

- Pt50 (385)
- Pt100 (385)
- Pt200 (385)
- Pt400 (385)
- Pt500 (385)
- Pt1000 (385)
- Pt100 (3926)
- Pt100 (391)
- Pt100 (375)
- Pt100 (3923)
- Ni100 (618)
- Ni120 (672)
- Cu10 (427)

¹) Uncertainty includes reference standard uncertainty, hysteresis, nonlinearity, repeatability and typical long term stability for mentioned period. (k=2)

²) Specification valid with an excitation current
>0.2 mA (0...400 ohm),
>0.1 mA (400...4000 ohm)

RTD Types Available as Option

- Pt25 (3926)
- Pt200 (3926)
- Pt470 (3926)
- Pt500 (3926)
- Pt50 (3916)
- Pt100 (3916)
- Pt200 (3916)
- Pt400 (3916)
- Pt500 (3916)
- Pt1000 (3916)
- Pt25 (391)
- Pt120 (391)
- Pt130 (391)
- Pt500 (391)
- Pt1000 (375)
- Pt100 (389)
- Pt10 (3923)
- Pt50 (3924)
- Pt100 (3924)
- Pt200 (3924)
- Pt500 (3924)
- Pt1000 (3924)
- Ni50 (618)
- Ni120 (618)
- Ni1000 (618)
- Ni50 (672)
- Ni50 (672)
- Ni100 (672)
- Ni1000 (672)
- NiFe604 (518)
- NiFe1000 (527)
- NiFe2000 (527)
- NiFe3000 (262)
- Cu100 (427)
- Cu10 (426)
- Cu50 (426)
- Cu53 (426)
- Cu100 (426)
- Cu 10M (428)
- Cu 50M (428)
- Cu 100M (428)
- Cu 10M (426)
- Cu 50M (426)
- Cu 53M (426)
- Cu 100M (426)

Thermocouple Measurement and Simulation

Common features for thermocouple types available as standard:

Feature	Specification
Temperature coefficient	< ±0.0015% of thermovoltage / °C outside of 18...28°C < ±0.0008% of thermovoltage / °F outside of 64.4 ...82.4°F
Supported units	°C, °F, K
Input impedance (measurement)	>10 Mohm
Display update rate (measurement)	3 / second
Max. load current (generation)	5 mA
Load effect (generation)	< 5uV/mA

Type B⁽²⁾

Full Range: 0 ... 1820 °C		
Sub Range	Resolution	1 Year Uncertainty ⁽¹⁾ (±)
0 ... 200	0.01 °C	⁽³⁾
200 ... 500	0.01 °C	2.0 °C
500 ... 800	0.01 °C	0.8 °C
500 ... 1820	0.01 °C	0.6 °C

Type R⁽²⁾

Full Range: -50 ... 1768		
Sub Range	Resolution	1 Year Uncertainty ⁽¹⁾ (±)
-50 ... 0	0.01 °C	0.01 °C
0 ... 50	0.01 °C	0.01 °C
50 ... 1400	0.01 °C	0.01 °C
1400 ... 1768	0.01 °C	0.01 °C

- 1) Uncertainty includes reference standard uncertainty, hysteresis, nonlinearity, repeatability and typical long term stability for mentioned period. (k=2). Uncertainty does not include reference junction uncertainty.
- 2) IEC 584, NIST MN 175, BS 4937, ANSI MC96.1
- 3) ±0.02 % of thermovoltage + 4 µV

Type S²

Full Range: -50 ... 1768		
Sub Range	Resolution	1 Year Uncertainty ⁽¹⁾ (±)
-50 ... 0	0.01 °C	1.0 °C
0 ... 50	0.01 °C	0.7 °C
50 ... 1500	0.01 °C	0.6 °C
0 ... 1768	0.01 °C	0.7 °C

Type E²

Full Range: -270 ... 1000 °C		
Sub Range	Resolution	1 Year Uncertainty ⁽¹⁾ (±)
-270 ... -200	0.01 °C	⁽³⁾
-200 ... 0	0.01 °C	0.07 °C + 0.08 % rdg
0 ... 600	0.01 °C	0.07 °C + 0.015 % rdg
600 ... 1000	0.01 °C	0.026 % rdg

Type J²

Full Range: -210 ... 1200 °C		
Sub Range	Resolution	1 Year Uncertainty ⁽¹⁾ (±)
-210 ... -200	0.01 °C	⁽³⁾
-200 ... 0	0.01 °C	0.25 °C
0 ... 1200	0.01 °C	

Type K²

Full Range: -270 ... 1372 °C		
Sub Range	Resolution	1 Year Uncertainty ⁽¹⁾ (±)
-270 ... -200	0.01 °C	⁽³⁾
-200 ... 0	0.01 °C	0.1 °C + 0.1 % rdg
0 ... 1000	0.01 °C	0.1 °C + 0.02 % rdg
1000 ... 1372	0.01 °C	0.03 % rdg

¹⁾ Uncertainty includes reference standard uncertainty, hysteresis, nonlinearity, repeatability and typical long term stability for mentioned period. (k=2).
Uncertainty does not include reference junction uncertainty.

²⁾ IEC 584, NIST MN 175, BS 4937, ANSI MC96.1

³⁾ ±0.02 % of thermovoltage + 4 µV

Type N⁽²⁾

Full Range: -270 ... 1300 °C		
Sub Range	Resolution	1 Year Uncertainty ⁽¹⁾ (±)
-270 ... -200	0.01 °C	⁽³⁾
-200 ... -100	0.01 °C	0.02 % rdg
-100 ... 0	0.01 °C	0.15 °C + 0.05 % rdg
0 ... 750	0.01 °C	0.15 °C + 0.01 % rdg
750 ... 1300	0.01 °C	0.03 % rdg

Type T⁽²⁾

Full Range: -270 ... 400 °C		
Sub Range	Resolution	1 Year Uncertainty ⁽¹⁾ (±)
-270 ... -250	0.01 °C	⁽³⁾
-250 ... -200	0.01 °C	0.7 °C
-200 ... 0	0.01 °C	0.1 °C + 0.1 % rdg
0 ... 400	0.01 °C	0.1 °C + 0.01 % rdg

Type U⁽⁴⁾

Full Range: -200 ... 600 °C		
Sub Range	Resolution	1 Year Uncertainty ⁽¹⁾ (±)
-200 ... 0 °C	0.01 °C	0.15 °C + 0.1 % rdg
0 ... 600 °C	0.01 °C	0.15 °C + 0.01 % rdg

Type L⁽⁴⁾

Range	Resolution	1 Year Uncertainty ⁽¹⁾ (±)
-200 ... 0	0.01 °C	0.13 °C + 0.07 % rdg
0 ... 900	0.01 °C	0.13 °C + 0.02 % rdg

Type C⁽⁵⁾

Full Range: 0 ... 2315 °C		
Sub Range	Resolution	1 Year Uncertainty ⁽¹⁾ (±)
0 ... 900	0.01 °C	0.4 °C
900 ... 2000	0.01 °C	0.045 % rdg
2000 ... 2315	0.01 °C	1.2 °C

- 1) Uncertainty includes reference standard uncertainty, hysteresis, nonlinearity, repeatability and typical long term stability for mentioned period. (k=2).
Uncertainty does not include reference junction uncertainty.
- 2) IEC 584, NIST MN 175, BS 4937, ANSI MC96.1
- 3) ±0.02 % of thermovoltage + 4 µV
- 4) DIN 43710
- 5) ASTM E 988 - 96

Type G⁶

Full Range: 0 ... 2315 °C		
Sub Range	Resolution	1 Year Uncertainty ⁽¹⁾ (±)
0 ... 70	0.01 °C	⁽³⁾
70 ... 200	0.01 °C	1.0 °C
200 ... 1600	0.01 °C	0.5 °C
1600 ... 2000	0.01 °C	0.7 °C
2000 ... 2315	0.01 °C	1.0 °C

Type D⁵

Full Range: 0 ... 2315 °C		
Sub Range	Resolution	1 Year Uncertainty ⁽¹⁾ (±)
0 ... 1000 °C	0.01 °C	0.4 °C
1000 ... 2000 °C	0.01 °C	0.04 % rdg
2000 ... 2315 °C	0.01 °C	1.2 °C

Thermocouple Types Available as Option

- K+/Au0.07Fe ⁽⁶⁾
- Ni18Mo/Ni0.8Co ⁽⁶⁾
- Platinel II ⁽⁶⁾
- Au/Pt ⁽⁶⁾
- Pt40Rh/Pt20Rh ⁽⁶⁾
- Ir40Rh/Ir ⁽⁶⁾
- Pt5Mo/Pt0.1Mo ⁽⁶⁾

Internal Reference Junction

Range	1 Year Uncertainty ⁽¹⁾ (±)
-10 ... 50 °C	0.25 °C

¹⁾ Uncertainty includes reference standard uncertainty, hysteresis, nonlinearity, repeatability and typical long term stability for mentioned period. (k=2).
Uncertainty does not include reference junction uncertainty.

³⁾ ±0.02 % of thermovoltage + 4 µV

⁵⁾ ASTM E 988 - 96

⁶⁾ ASTM E 1751 - 95e1

Pressure Modules

Internal Pressure Modules (NPM)

Module	Unit	Range ⁽²⁾	Resolution	1 Year Uncertainty ⁽¹⁾
Barometric option	kPa a	80 ... 120	0.01	0.1 kPa
	mbar a	800 ... 1200	0.1	1 mbar
	psi a	11.6 ... 17.4	0.001	0.0146 psi
NPM200mC	kPa	±20	0.001	0.035 % FS + 0.05 %rdg
	mbar	±200	0.01	
	iwc	±80	0.001	
NPM2C	kPa	-100 ... 200	0.001	0.015 % FS + 0.035 %rdg
	bar	-1 ... 2	0.00001	
	psi	-14.5 ... 30	0.001	
NPM20C	kPa	-100 ... 2000	0.01	0.015 % FS + 0.035 %rdg
	bar	-1 ... 20	0.0001	
	psi	-14.5 ... 300	0.01	
NPM160	MPa	0 ... 16	0.0001	0.015 % FS + 0.035 %rdg
	bar	0 ... 160	0.001	
	psi	0 ... 2400	0.01	

Term 'FS':

'FS' is the Full Scale of the positive side range. E.g. for ±200 mbar module, the Full Scale is 200 mbar.

Barometric option:

Enables also absolute pressure measurement for above mentioned pressure inputs.

With barometric option add 0.1 kPa (0.0146 psi) uncertainty for absolute pressure measurement.

1) Uncertainty includes reference standard uncertainty, hysteresis, non-linearity, repeatability and typical long term stability for mentioned period (k=2).

2) Every internal/external pressure module's range may be displayed also in absolute pressure if the Barometric Module (B) is installed.

Feature	Specification
Temperature coefficient	<±0.001 % Rdg/°C outside 15...35°C (59 ... 95 °F)
Maximum overpressure	Barometric Option: 1200 mbar abs (35.4 inHg abs) Others: 2 × Range
Pressure port	Barometric option: M5 (10/32") female NPM160: G 1/8" female (parallel) All others: G1/8" (ISO228/1) female. A conical 1/8" BSP male with 60° internal cone adapter included for Beamex hose set.
Wetted parts	AISI316 stainless steel, Nitrile rubber.
Pressure media	Barometric option: Dry clean air or other clean, inert, non-toxic, non-corrosive gases All others: Clean, inert, non-toxic, non-corrosive gases or liquids Use of pressure media classified as dangerous is prohibited.
Supported pressure units	Pa, hPa, kPa, MPa, mbar, bar, lbf/ft ² , psi, osi, gf/cm ² , kgf/cm ² , kgf/m ² , kp/cm ² , at, mmH ₂ O, cmH ₂ O, mH ₂ O, iwc, ftH ₂ O, mmHg, cmHg, mHg, inHg, mmHg(0°C), inHg(0°C), mmH ₂ O(4°C), inH ₂ O(4°C), ftH ₂ O(4°C), inH ₂ O(60°F), mmH ₂ O(68°F), inH ₂ O(68°F), ftH ₂ O(68°F), torr, atm, + four (4) user configurable units
Operating temperature	-10...+50°C (14...122 °F)
Storage temperature	-20...+60°C (-4...140 °F)
Humidity range	0...80 % R.H. non-condensing
Display update rate	2.5 / second

External Pressure Modules (EXT), High Accuracy

Module	Unit	Range ³⁾	Resolution	Accuracy ¹⁾ (±)	1 Year Uncertainty ²⁾ (±)
EXT B	kPa a mbar a psi a	80 to 120 800 to 1200 11.6 to 17.4	0.01 0.1 0.001	0.3 mbar	0.05 kPa 0.5 mbar 0.0073 psi
EXT10mD	kPa diff mbar diff iwc diff	± 1 ± 10 mbar diff ± 4	0.001	0.05 % Span	0.05 % Span + 0.1 % RDG
EXT100m	kPa mbar iwc	0 to 10 0 to 100 0 to 40	0.0001 0.001 0.001	0.015 % FS + 0.0125 % RDG	0.025 % FS + 0.025% RDG
EXT400mC	kPa mbar iwc	± 40 ± 400 ± 160	0.001 0.01 0.001	0.01 % FS + 0.0125 % RDG	0.02 % FS + 0.025% RDG
EXT1C	kPa bar psi	± 100 ± 1 -14.5 to 15	0.001 0.00001 0.0001	0.007 % FS + 0.0125 % RDG	0.015 % FS + 0.025% RDG
EXT2C	kPa bar psi	-100 to 200 -1 to 2 -14.5 to 30	0.001 0.00001 0.0001	0.005 % FS + 0.01 % RDG	0.01 % FS + 0.025% RDG
EXT6C	kPa bar psi	-100 to 600 -1 to 6 -14.5 to 90	0.01 0.0001 0.001	0.005 % FS + 0.01 % RDG	0.01 % FS + 0.025% RDG
EXT20C	kPa bar psi	-100 to 2000 -1 to 20 -14.5 to 300	0.01 0.0001 0.001	0.005 % FS + 0.01 % RDG	0.01 % FS + 0.025% RDG
EXT60	kPa bar psi	0 to 6000 0 to 60 0 to 900	0.1 0.001 0.01	0.005 % FS + 0.0125 % RDG	0.01 % FS + 0.025% RDG
EXT100	MPa bar psi	0 to 10 0 to 100 0 to 1500	0.0001 0.001 0.01	0.005 % FS + 0.0125 % RDG	0.01 % FS + 0.025% RDG
EXT160	MPa bar psi	0 to 16 0 to 160 0 to 2400	0.0001 0.001 0.01	0.005 % FS + 0.0125 % RDG	0.01 % FS + 0.025% RDG
EXT250	MPa bar psi	0 to 25 0 to 250 0 to 3700	0.001 0.01 0.1	0.007 % FS + 0.0125 % RDG	0.015 % FS + 0.025% RDG
EXT600	MPa bar psi	0 to 60 0 to 600 0 to 9000	0.001 0.01 0.1	0.007 % FS + 0.01 % RDG	0.015 % FS + 0.025% RDG
EXT1000	MPa bar psi	0 to 100 0 to 1000 0 to 15000	0.001 0.01 0.1	0.007 % FS + 0.01 % RDG	0.015 % FS + 0.025% RDG

Term 'FS':

'FS' is the Full Scale of the positive side range. E.g. for ±200 mbar module, the Full Scale is 200 mbar.

- 1) Accuracy includes hysteresis, nonlinearity, repeatability and reference standard uncertainty (k=2).
- 2) 1 Year Uncertainty includes hysteresis, nonlinearity, repeatability and typical long term stability for mentioned period (k=2).
- 3) Every internal/external pressure module's range may be displayed also in absolute pressure if the Barometric Module (B) is installed.

Feature	Specification
Temperature coefficient	EXT10mD: < ±0.002 % Span/°C outside 15 ... 35 °C (59... 95 °F) All other modules: <±0.001 % Rdg/°C outside 15 ... 35 °C (59... 95 °F)
Maximum overpressure	See table below
Pressure port	EXT B: M5 (10/32") female EXT10mD: Two M5 (10/32") female threads. Hose nipples for hoses with an inner diameter of approx. 3.2 mm (1/8") included. Hose included. EXT100m, EXT400mC, EXT1C, EXT2C, EXT6C, EXT20C: G1/8" (ISO228/1) female. A conical 1/8" BSP male with 60° internal cone adapter included for Beamex hose set. EXT60 to EXT1000 G 1/4" (ISO228/1) male
Wetted parts	AISI316 stainless steel, Hastelloy, Nitrile rubber.
Pressure media	EXT B to EXT 6C: Dry clean air or other clean, inert, non-toxic, non-corrosive gases EXT60 to EXT1000: Clean, inert, non-toxic, non-corrosive gases or liquids Use of pressure media classified as dangerous is prohibited.
Dimensions, length / width / depth	145 mm / 45 mm / 55 mm (5.7" / 1.8" / 2.2")
Weight	0.5 kg (1.1 lb)
Operating temperature	-10...+50°C (14...122 °F)
Storage temperature	-20...+60°C (-4... 140 °F)
Humidity range	0...80 % R.H. non-condensing

Module	Maximum overpressure	Module	Maximum overpressure
EXT B	1200 mbar abs 35.4 inHg abs	EXT20C	40 bar 600 psi
EXT10mD	200 mbar 80 iwc	EXT60	120 bar 1800 psi
EXT100m	200 mbar 80 iwc	EXT100	200 bar 3000 psi
EXT400mC	800 mbar 320 iwc	EXT160	320 bar 4800 psi
EXT1C	2 bar 30 psi	EXT250	500 bar 7400 psi
EXT2C	4 bar 60 psi	EXT600	900 bar 13000 psi
EXT6C	12 bar 180 psi	EXT1000	1000 bar 15000 psi

Note.

The sensor unit of EXT1000/EXT1000-IS withstands 10000 full range pressure cycles. Exceeding the maximum amount of pressure cycles may result in leakage or even explosion.

External Pressure Modules (EXT), Standard Accuracy

Module	Unit	Range ²	Resolution	1 Year Uncertainty ¹
EXT200mC-s	kPa	±20	0.001	0.05% RDG + 0.05% FS
	mbar	±200	0.01	
	iwc	±80	0.01	
EXT2C-s	kPa	-100 ... 200	0.01	0.05% FS
	bar	-1 ... 2	0.0001	
	psi	-14.5 ... 30	0.001	
EXT20C-s	kPa	-100 ... 2000	0.1	0.05% FS
	bar	-1 ... 20	0.001	
	psi	-14.5 ... 300	0.01	
EXT160-s	MPa	0 ... 16	0.001	0.05% FS
	bar	0 ... 160	0.01	
	psi	0 ... 2400	0.1	

Term 'FS':

'FS' is the Full Scale of the positive side range. E.g. for ±200 mbar module, the Full Scale is 200 mbar.

Feature	Specification
Temperature coefficient	<±0.001 % Rdg/°C outside 15...35°C (59 ... 95 °F)
Maximum overpressure	2 × Range
Pressure port	EXT160-s: G 1/8" female (parallel) All others: G1/8" (ISO228/1) female. A conical 1/8" BSP male with 60° internal cone adapter included for Beamex hose set.
Wetted parts	AISI316 stainless steel, Hastelloy, Nitrile rubber.
Pressure media	EXT200mC-s and EXT2C-s: Dry clean air or other clean, inert, non-toxic, non-corrosive gases EXT20C-s and EXT160-s: Clean, inert, non-toxic, non-corrosive gases or liquids Use of pressure media classified as dangerous is prohibited.
Dimensions, length / width / depth	145 mm / 45 mm / 55 mm (5.7" / 1.8" / 2.2")
Weight	0.5 kg (1.1 lb)
Operating temperature	-10...+50°C (14... 122 °F)
Storage temperature	-20...+60°C (-4... 140 °F)
Humidity range	0...80 % R.H. non-condensing

1) Uncertainty includes reference standard uncertainty, hysteresis, non-linearity, repeatability and typical long term stability for mentioned period (k=2).

2) Every internal/external pressure module's range may be displayed also in absolute pressure if the Barometric Module (B) is installed.

All standard accuracy external pressure modules are also compatible with Beamex MC5 and MC5P Calibrators (firmware version 1.90 and onwards).

All specifications are subject to change without prior notice

Appendix 3, Index

2

2-wire system 119

A

About MC4, Window 96

About This Manual 3

Absolute Error 181

Accepting Calibration Points

Automatically 178

Acknowledging Alarms 70

Additional Calibration Related

Information 177

Additional Info Row 90

Bar Graph 93

Barometric Pressure 92

Clearing 93

Cumulative Average 91

Deviation Reference 91

Difference Measurement 91

Feedback Measurement 92

Icons 90

Internal Temperature 91

Maximum value 90

Maximum-Minimum 91

Minimum value 90

Normal Reading 91

Pulses Done 93

Pulses Left 93

Rate of Change 90

Redundant Measurement 91

Redundant Reference 91

Resetting Calculations 93

RJ Temperature

Measurement 92

RTD Measurement 92

Sensor Resistance 92

Thermovoltage Measurement 92

Additional Information 109

Calibration Related 177

Adjustment Note 180

Adjustment of Instruments 126, 145

After Calibration Note 180

Alarms 69, 149

Acknowledging 70

Resetting 70

As Found calibration 126

As Left calibration 127

Automatically Accepting

Calibration Points 178

Auto-off Delays 99

B

Bag 26

Bar Graph 93

Barometric Pressure 92

Barometric Pressure Module 7

Basic Mode, Defined 37

Batteries 11, 25

Charging 12

Removing/Replacing 13

Before Calibration Note 172, 180

C

Calibration

Accepting Points 132, 178

Additional Information 177

Adjustment 126, 145

As Found 126

As Left 127

Barometric Module 177

Barometric Pressure 177

Cancelling 147

Changing EXT Module 179

Combining Repeats 182

Creating Instruments 151, 155, 156

Creating Plant Structure

Levels 151

Deleting Results 176

Device Data 158

Edit Instrument 146, 150, 156

Electrical Limit Switch	142	Calibration Notes	
Ending.....	145, 147	Adjustment.....	172, 180
Environment Pressure Unit.....	154	After Calibration.....	172, 180
Environmental Data	180	Before Calibration.....	172, 180
Error Calculation	181	Point Level Notes	180
Error Graph Scaling	154	Calibration Points, Custom	101
Examples	133	Calibration Results	
Extra Information Saved with		Deleting	176
Results.....	177	Memory.....	182
Failed Calibration, Symbol.....	176	Viewing	174, 175
Function Data	163	Calibrator	
Function Info.....	149	Recalibration.....	100
General Data	172	Callendar - Van Dusen	
General Procedure	130	Equation.....	107
Generally	124	Cancelling Calibration	147
Identifying an Instrument	157	Capacity indication	14
Information.....	145, 147	Carrying Case	26
Input Data	159	Case	26
Instrument Database	150, 156	Change Rate.....	90
Instrument Input.....	146, 148	Resetting	93
Instrument List.....	129, 151	Changing EXT Module	
Instrument Output.....	146, 148	Basic Mode.....	44
Maintaining Instruments ...	150, 153, 154, 156	During Calibration.....	179
Memory.....	182	Changing	
Output Data	161	Generation/Simulation	
Passed Calibration, Symbol	176	Values.....	54
Pausing.....	147	Charger.....	33
Phases.....	125	Check Boxes	24
Plant Structure.....	129, 151	Cleaning MC4	34
Pneumatic Pressure		Clearing the Additional Info	
Transmitter.....	140	Row.....	93
Position Data	157	Combining Calibration	
Pressure Converter	140	Repeats.....	182
Pressure Transmitters	134	Communication	15
Procedure Data	165	Configuration Windows	20
Reference Sensor.....	177	Connecting/Disconnecting a	
Resolution.....	177	Pressure Module	44, 149, 179
Results.....	146, 148, 152	Connections	6
Deleting	153	Internal Pressure Modules	7
RJ Sensor.....	177	Connectors.....	8
Save As Both	154	Contrast of the Display	9
Saving	132, 147	Copying Instruments	153, 155
Saving Instrument Data	173	Copying Plant Structures.....	153
Selecting the Instrument.....	129	Creating	
Settings.....	154	Instruments.....	151, 155, 156
Skip Point.....	147	Plant Structure Levels	151
Supported Combinations	128	Creating Instruments	154
Switch	142	Creating Plant Structures	
Temperature Indicators	136	Levels.....	154
Temperature Recorders	136	Cumulative Average	91
Temperature Sensors.....	138	Current Generation.....	56
Undo Point.....	147	Current Measurement	41
Viewing Results	174, 175		
Window Menu.....	145		
Zeroing a Pressure Module	180		

Customizing		Error %	82
Auto Off Delays	99	Error Calculation Formulas	181
Date and Time Format	98	Error Graph Scaling	154
Language	99	Error in Input Units	83
Net Frequency	99	Error in Output Units	84
Owner Info	99	Error Limit Data Fields	
Pressure Units	108	Adjust if >	170
PRT Sensors	106	Adjust to <	170
Temperature Scale	99	Display Resolution	170
Temperature Units	99	Do not adjust if <	170
Test Point Sets	101	Error Calculation Domains, Reset Point	170
Transfer Functions	103	Error Calculation Domains, Set Point	170
User Setups	97	Error Calculation Method	170
Volume	99	Reject if >	170, 171
		Use Separate Switch Reset Point Error Limits	171
D		Error situations in thermocouple measurement	117
Damping	70, 149	EXT Connector	8
Date Format	98	EXT Module	
Deleting Calibration		Changing	44, 149, 179
Results	153, 176	External Reference Junction	114
Deleting Instruments	153	Extra Info Row	90
Deleting Plant Structures	153	Extra Information Saved with Results	177
Deviation Measurement	87		
Deviation Reference	91	F	
Device Data Fields		Factors	107
Device ID	158	Feedback Measurement	92
Manufacturer	158	Fields	
Model	158	Check Boxes	24
Sensor Serial Number	158	Device Data	158
Serial Number	158	Error Limit Data	170
Difference Measurement	89, 91	Function Data	163
Display		General Data	172
Contrast	9	Input Data	159
Display Modes	81, 149	Numeric Fields	21
Error %	82	Output Data	161
Error in Input Units	83	Position Data	157
Error in Output Units	84	Procedure Data	165
Percentage	85	Selection Lists	23
Scaling	86	Text Fields	22
Driver for USB	15	Firmware	
Dry Batteries	25	Basic Mode	17
		Calibration Mode	17, 124
E		Check Boxes	24
Edit Instruments	150, 156	Configuration Windows	20
Electrical Limit Switch Calibration	142	Function Keys	19
Ending Calibration	147	Menu	19
Entering		Numeric Fields	21
Generation/Simulation Values	54	Selection Lists	23
Environment Pressure Unit	154	Status Bar	18
Environmental Data	180	Text Fields	22
Equation	107	Updating	17, 33
Equations, Error Calculation	181	User Interface	18

Frequency Generation 58, 59
 Frequency Measurement 42
 Function Data 163
 Function Data Fields
 Channel Name 164
 Channel Number 164
 Function Name 164
 Input Range 163
 Nominal Reset 163
 Nominal Set 163
 Output Range 163
 Set Action 163
 Transfer Function 163
 Function Info, Basic Mode 68
 Function Info, Calibration 149
 Function Keys 19

G

General Data 172
 General Data Fields
 Adjustment Note 172
 After Calibration Note 172
 Before Calibration Note 172
 Calibration Interval 172
 Number of Calibration
 Repeats, As Found 172
 Number of Calibration
 Repeats, As Left 172
 Work Order 172
 General Settings 99
 Generating (see also
 Simulating)
 Current 56
 Entering Values 54
 Frequency 58, 59
 General Description 53
 Manual Stepping 54
 Spinning 54
 Voltages 65

H

Hardware 5

I

Icons 90

Input Data Fields
 Amplitude 160
 Display Resolution 159
 External Supply 160
 Function 159
 HART Compatible Loop
 Supply 159
 RJ Mode 159
 Sensor 159
 Switch Sound 160
 Trigger Edge 160
 Trigger Level 160
 Unit 159
 Waveform 160

Instrument
 Copying 153, 155
 Creating 154, 155
 Deleting 153
 Device Data 158
 Function Data 163
 General Data 172
 Identifying 157
 Input 146, 148
 Input Data 159
 Output 146, 148
 Output Data 161
 Position Data 157
 Procedure Data 165
 Saving Data 173
 Selecting 129, 152
 Viewing Details 152
 Instrument Database 150, 156
 Instruments
 Creating 151
 Internal Pressure Modules 7
 Internal Reference Junction 113
 Internal Temperature 91

K

Keyboard
 Arrow Keys 10
 Backlight Key 10
 Enter Key 10
 Function Keys 10
 Numeric Keys 10
 On/Off Key 10
 Keying Values into MC4 66

L

Language	99, 179
Leak Test	71, 149
Limit Switch Calibration	142

M

Maintaining Instruments .	150, 153, 154, 156
Manual Stepping	54, 78
Manually Keyed Values	66
Maximum value	90
Maximum Value	
Resetting	93
Maximum-Minimum	91
Measurement	
Test Diode Connections	120
Measuring	
Current	41
Frequencies	42
General Description	39
Pressure	43
Switch State Sensing	48
Voltages	52
Memory	9, 97, 102, 105, 150, 155, 182
Menu in Calibration Window	145
Minimum value	90
Minimum Value	
Resetting	93

N

Net Frequency	99
Normal Reading	91
Numeric Fields	21

O

Option Connector	8
Options	25
Carrying Case	26
Dry Batteries	25
EXT Connection Cable	26
Pressure Hose	25
Pressure Modules	25
Thermocouple Mini Plugs	26
Output Data	161

Output Data Fields	
Display Resolution	161
Function	161
HART Compatible Loop	
Supply	161
Invert Switch Open/Closed	
States	162
RJ Mode	161
Sensor	161
Switch Sound	162
Trigger Edge	162
Trigger Level	162
Unit	161
Owner	99

P

Parallel Functions in MC4	121
Pausing Calibration	147
PC Communication, Driver	15
Percent of Output Span Error	181
Percentage Display	85
Plant Structure	129, 151
Browsing	151
Copying	153
Creating	151, 154
Deleting	153
Viewing Details	152
Pneumatic Pressure	
Transmitter Calibration	140
Position Data Fields	
Position ID	157
Position Location	157
Position Name	157
Power Connector	8
Pressure	
Module Names	111
Pressure Types	110
Square Rooting Instruments	112
Pressure Converter	
Calibration	140
Pressure Hose	25
Pressure Measurement	43
Pressure Module	
Connecting/Disconnecting	44, 149, 179
Zeroing	45, 180
Pressure Modules	
Barometric	7
Connections	7
Gauge	7
Pressure Transmitter	
Calibration	134
Pressure Units, Custom	108

Procedure Data..... 165

Procedure Data Fields

- Automatic Calibration Point
- Acceptance..... 166, 167
- Calibration Points..... 165
- Checking Range..... 167
- Final Ramp Delay..... 169
- Limited Checking Range for
- Pass/Fail Detection..... 167
- Max Point Deviation..... 166
- Repeat Format..... 165
- Require also Stable Output
- Measurement..... 166
- Reset Point..... 168
- Setpoint Delay..... 166
- Step Response Wait..... 168
- Supervised Advancement to
- Next Calibration Point..... 167
- Switch Ramp/Scan Ranges..... 167
- Switch Test Cycles..... 169
- Update Switch Scan Range
- Automatically..... 168
- Use Prescan..... 168

PRT Sensors, Custom..... 106, 107

Pulses Done..... 93

Pulses Left..... 93

R

Ramping..... 76

Rate of Change..... 90

- Resetting..... 93

Recalibrating MC4..... 100

Redundant Measurement..... 88, 91

Redundant Reference..... 91

Reference Junction

- External..... 114
- Internal..... 113
- Modes..... 113, 114

Related Information..... 109

Resetting Alarms..... 70

Resetting MC4..... 33

Resetting min/max/rate

- Calculations..... 93

Resistance Simulation..... 60

Resolution..... 66

Results

- Saved Extra Information..... 177

RJ Temperature

- Measurement..... 92

RTD Connections..... 118

RTD Measurement..... 92

RTD Sensor Simulation..... 61

RTD Sensor Types

- Optional..... 193
- Standard..... 192

S

Safety..... 27

Save As Both..... 154

Saving a Calibration..... 132, 147

Saving Instrument Data..... 173

Scaling..... 86

Selecting the instrument to

- be calibrated..... 129, 151, 152

Selection Lists..... 23

Sensor Resistance..... 92

Service..... 33

Setpoint Delay..... 166, 178

Settings

- Auto-off Delays..... 99
- Date and Time (Format)..... 98
- Language..... 99, 179
- Net Frequency..... 99
- Owner..... 99
- Temperature Scale..... 99
- Temperature Unit..... 99
- User Setups..... 97
- Volumes..... 99

Simulating (see also

- Generating)
- Resistance..... 60
- RTD Sensors..... 61
- Thermocouples..... 63

Simultaneous

- measurement/generation/sim
- ulation..... 121

Sinking Current..... 56

Skip Calibration Point..... 147

Software..... 17, 33

Sourcing Current..... 56

Special Generations

- Manual Stepping..... 78
- Ramping..... 76
- Stepping..... 73

Special Measurements..... 81, 149

- Damping..... 70
- Deviation Measurement..... 87
- Difference Measurement..... 89
- Redundant Measurement..... 88
- Tare..... 87

Specifications

Current Generation.....	188
Current Measurement.....	185
Frequency Generation.....	190
Frequency Measurement.....	186
General.....	184
Internal Reference Junction.....	197
Milliamp Generation.....	188
Millivolt Generation.....	187
Millivolt Measurement.....	187
Pressure Modules, External, High Accuracy.....	200
Pressure Modules, External, Standard Accuracy.....	202
Pressure Modules, Internal.....	198
Pulse Counting.....	186
Pulse Generation.....	190
Resistance Measurement.....	189
Resistance Simulation.....	189
RTD	
Cu10.....	192
Ni100.....	191
Ni120.....	192
RTD Measurement.....	191
RTD Simulation.....	191
RTDPlatinum.....	191
Switch Test.....	186
Thermocouple	
Type B.....	194
Type C.....	196
Type D.....	197
Type E.....	195
Type G.....	197
Type J.....	195
Type L.....	196
Type N.....	196
Type R.....	194
Type S.....	195
Type T.....	196
Type U.....	196
Thermocouple Measurement.....	194
Thermocouple Simulation.....	194
Voltage Generation.....	187, 188
Voltage Measurement.....	185, 187
Spinning.....	54
Stability Test.....	71, 149
Stand.....	9
Starting MC4.....	17, 36
Status Bar.....	18
Stepping.....	73
Support.....	9
Switch Calibration.....	142
Switch State Sensing.....	48

Symbols

2-Wire RTD Connection.....	119
3-Wire RTD Connection.....	118
4-Wire RTD Connection.....	118
Alarms.....	69
Barometric Pressure.....	92
Compensation Loop, RTD.....	119
Cumulative Average.....	91
Deviation Reference.....	91
Difference.....	91
Failed Calibration.....	150, 176
Maximum Value.....	90
Maximum-Minimum.....	91
Minimum Value.....	90
Normal Reading.....	91
Passed Calibration.....	150, 176
Pulses Done.....	93
Pulses Left.....	93
Rate of Change.....	90
Redundant Measurement.....	91
Redundant Reference.....	91
RJ Temperature.....	92
Sensor Resistance.....	92
Thermovoltage.....	92

T

Tare.....	87
Tasks, Simultaneous.....	121
Teaching capacity indication.....	14
Temperature Indicator	
Calibration.....	136
Temperature Recorder	
Calibration.....	136
Temperature Scale.....	99
Temperature Sensor	
Calibration.....	138
Temperature Unit.....	99
Terminals.....	8
Test Diode, Measurement	
Parallel to a.....	120
Test Point Sets, Custom.....	101
Testing Leakage/Stability.....	71, 149
Text Fields.....	22
Thermocouple Simulation.....	63
Thermocouple Types	
Optional.....	197
Thermovoltage Measurement.....	92

Tools..... 67

- Alarms..... 69, 149
- Damping 70, 149
- Deviation Measurement..... 87
- Difference Measurement 89
- Error %..... 82
- Error in Input Units..... 83
- Error in Output Units..... 84
- Function Info 68
- Leak/Stability Test 71, 149
- Manual Stepping..... 78
- Percentage Display 85
- Ramping 76
- Redundant Measurement..... 88
- Scaling 86
- Stepping..... 73
- Tare 87

Transfer Functions, Custom..... 103

Troubleshooting

- thermocouple measurement 117
- Typographical Conventions..... 3

U

- Undo Calibration Point 147
- Unpacking and Inspection..... 4
- Updating the Firmware..... 17, 33

- USB Connector 8
- USB Driver 15
- User Configurable Pressure
- Units..... 108
- User Interface..... 18
- User Setups 97

V

- Viewing Angle of the Display 9
- Viewing Calibration Results..... 174, 175
- Voltage Generation 65
- Voltage Measurement 52
- Volume Settings 99

W

- Warnings..... 28

Z

- Zeroing a Pressure Module 45, 180

